

Hawk Pro

Instruction Manual



SPECIFICATIONS

⇒ Main Rotor Diameter	49.5 in.
⇒ Tail Rotor Diameter	9.3 in.
⇒ Overall Length	46 in.
⇒ Height	16.2 in.
⇒ Engine	32 ~ 40
⇒ Ball Bearings	47

Century Helicopter Products

Designed and Developed in USA

1st Edition April 2005 All rights reserved.

Table of Contents

Table of Contents & Introduction	2
Required Items and Tools for Assembly	3
Package contents	4
Section 1 Preparing the engine	5
Section 2 Assembling the main frame	5
Section 3 Assembling the servo tray	6
Section 4 Fuel tank & fittings	6
Section 5 Muffler & fuel tubing	7
Section 6 Flybar & rotor head assembly	7
Section 7 Landing gear	8
Section 8 Tail boom & drive system	8
Section 9 Tail boom support struts and tail fin set	9
Section 10 Tail control rod and pitch control	9
Section 11 Throttle & collective linkage	9
Section 12 Cyclic servo linkage	10
Section 13 Rotor head linkage	10
Section 14 Connect the electronics	10
Section 15 Main rotor blade installation	10
Section 16 Antenna routing	11
Section 17 Mounting the canopy	11
Main sub assemblies (exploded views)	12-17
Replacement part list and photos	18-20
Upgrades	21-22

Introduction

Congratulations on your purchase of Century Helicopter Product's latest version of our HAWK series RC helicopter model. The Hawk Pro helicopter is not only ideal for beginners new to the hobby, but also for the intermediate and right on through to the expert and 3D flyers. A 6 channel helicopter radio is recommended as the bare minimum to take advantage of the helicopter programming included in these radios. The expert to 3D flyers would certainly be using a good 8 to 10 channel helicopter radio. You may wish to check with us or your local dealer for compatible components.

Warning

This radio controlled model is not a toy! It is a precision machine requiring proper assembly and setup to avoid accidents. It is the responsibility of the owner to operate this product in a safe manner as it can inflict serious injury. It is recommended that if you are in doubt of your abilities, seek assistance from experienced radio control helicopter modelers and associations. As manufacturer, we assume no liability for the use of this product.

Pre-assembly Information

Upon opening the kit, all the major component parts are packaged in numbered bags to correspond to specific sections of the manual, greatly facilitating assembly. Various assemblies have been pre-assembled, only requiring the final assembly and installation of the various sub-assemblies. The screws and nuts required for each step are packaged in the same bag as the parts for that step. Be careful not to lose any of the hardware when opening each bag. Care has been taken in filling and packing of each bag.

Warranty

Your new equipment is warranted to the original purchaser against manufacturer defects in material and workmanship for 30 days from the date of purchase. During this period, Century Helicopter Products will repair or replace, at our discretion, any component that is found to be factory defective at no cost to the purchaser. This warranty is limited to the original purchaser and is not transferable. This warranty does not apply to any unit which has been improperly installed, mishandled, abused, or damaged in a crash, or to any unit which has been repaired or altered by any unauthorized agencies. Under no circumstances will the buyer be entitled to consequential or incidental damages. This limited warranty gives you specific legal rights. You also have other rights which may vary from state.

Century Helicopter Products

1740 Junction Ave. C.

San Jose, CA 95112

Fax: (408) 451-1156

www.centuryheli.com

Required items for operation

This is the general list of items required to get started on any nitro R/C helicopter. Century produces a full spectrum of accessories and tools to assemble your helicopter. The Hawk Pro is a mechanical cyclic collective pitch mixing type helicopter requiring a standard helicopter radio (the helicopter radio does not require eCCPM type mixing for this model). The Hawk Pro uses 5 servos to operate critical systems. Gyroscopes are required to operate the model safely.

Necessary Items "Not Included" in the kit.

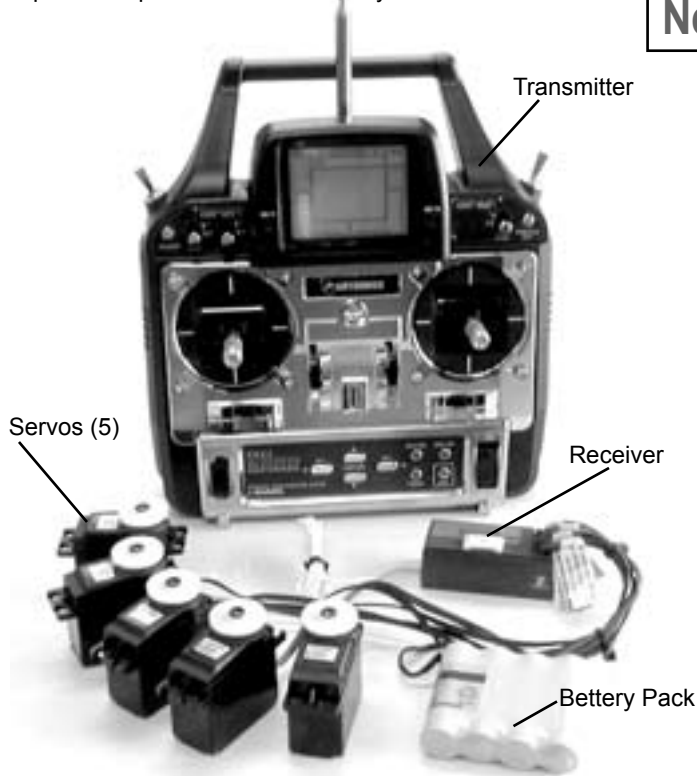

6 Channel Helicopter Radio or Equivalent.



#PG2000 II dual rate piezo gyro
#CN2018 (or equivalent)



Remote Glow Adapter
#CN2222 (optional)



32-40 Helicopter Engine



Tuned Muffler (example #CN3033)

Fastener and ball bearing dimensions

Hardware Description and Identification:

M3x6 = 3x6mm and can refer to screws or ball bearings.

M3x6 Phillips Machine Screw

M - metric
3 - diameter
6 - length

M3x6 Self Tapping Screw

M - metric
3 - diameter
6 - length

M3x10 Socket Cap Screw

M - metric
3 - diameter
6 - length

3x7 Ball Bearing

M - metric
3 - inside \varnothing
6 - outside \varnothing

Recommended Tools & Accessories

The tools and materials listed below are the minimum needed to build the helicopter:

In addition, the following will make assembly and setup easier, and prove useful later in your model toolbox:

- Screwdrivers - Slotted and Phillips head
- Long-Nosed Pliers.
- Allen Wrenches - 1.5mm, 2.0mm, 2.5mm (supplied in kit) + 3.0mm
- Appropriate Socket Wrench (glow plug wrench for engine shaft nut)
- Hobby Scissors
- Double Sided Foam Tape (1/16" - 3/32")
- Foam Rubber (radio packing)
- JB Weld (bond clutch lining)
- Thread lock liquid (e.g. Loctite)
- Hobby Grease (Super Lube)
- Oil to lubricate sliding shafts

- Part#CN2015
- Part#CN2026
- Part#CN2034A
- Part#CN2052
- Part#CN2054P
- Part#CN2055
- Part#CN2070
- Part#CN2155
- Part#CN2219
- Part#CN2255
- Part#CNWI26555
- Part#CNWI26570

- Hardened Tip Hex Screw Driver Set
- Pitch Gauge with Paddle Gauge
- 15° Curve Tip Ball link Pliers
- Main Blade Balancer
- Glow Plug Wrench Purple
- Ball Link Sizing Tool
- Universal Flybar Lock
- Piston Locking Tool
- Ball Link Easy Driver
- Control Rod Gauge
- 5.5mm Nut Driver
- 7.0mm Nut Driver

- CN2024T Lubrication
- Loctite CN2025BS blue
- CN2025RS red

15% or 30% Heli Fuel

12Volt Start Battery

Fuel Line

12Volt Starter

"Y" Harness for 4 Ch Airplane Radio with 5 servo
Main Blade Pitch Gauge w/PaddleGauge #CN2026

Hobby scissors

Needle Nose Plier & Cutter Pliers

Servo Tape

Glow Plug

Glow Driver w/Charger

Electric or Hand Fuel Pump

Package contents: Opening The Hawk Pro for the first time

Time to inventory your Hawk Pro! The helicopter is assorted into multiple bags contained inside the box. Each bag will have some parts that are not associated with that specific part bag. We recommend organizing all hardware and pieces and inventory them then keep them with their respective bags. It is common to have a few screws and/or washers left on the side after the build.



Tail section:

- Tail assembly (complete)
- Tail boom support struts (2)
- Flybar (1)
- *Antenna tube (1)

Rotor Head Items:

- Rotor head (complete)
- Flybar paddles (2)
- Paddle weights (2)
- 3x3 set screws (2) (for paddle weights)
- Flybar control arm (2)
- Double link (2) (flybar to washout arm)
- 4x5 set screws (2) (flybar control arms)
- 3x6x2.5 plastic spacer (2) (between flybar control arm and seesaw)
- 3x7x3 ball bearing (2) (flybar, inside seesaw bearing cups)

Upper frame set:

- Upper side frame assembly (complete)
- Aluminum canopy standoff (2)
- Canopy grommets (2)
- Canopy hook (1) (inside canopy)
- 3X40 threaded rod (1) (canopy standoffs)
- Horizontal fin upper clamp (1) (white plastic part that connects to fin)
- M3 lock nut (1)
- 3x20 Socket head cap screw (1)
- M3 locknut (1)
- 3x6 self tapping screw (2) (connects lower side frame to fan shroud)
- 3x12 Self tapping screws (4) (for servos)
- 3x16 Socket head cap screws (4) (not used/spares)

•3x8 flat washers (4)

- Rudder servo mount bracket (1)
- 3x30 socket head cap screws (2)
- Grey ball link (1) (rudder pushrod forward end)
- Servo mounting tabs (7)

Clutch, fan & shroud:

- Clutch (clutch and housing) (1)
- Cooling fan (1)
- Cooling fan shroud (1)
- Long aluminum tube (1)
- Short aluminum tube (1)
- Fuel fitting set (1 set)
- Tie wrap (1)
- Clunk (1)
- 3x18 self tapping screw (1) (fuel cap)
- 5 inches fuel tubing (1)
- 5x13 flat washer (1) (between cooling fan and engine nut)
- 9x14 flat washer (1) (replaces thrust washer on engine)
- 3x16 socket head cap screws(4)
- 3x8 self tapping screws (2)
- 3x12 self tapping screw (2)
- 3x6 washer head screws (2)

Hardware/Pushrods:

- 1 foot fuel tubing (1)
- Pushrods (5)
- 4x30 Socket head cap screws (2) (main blade bolts)
- M4 locknut (2)
- 2.5x12 self tapping screws (20) (servos)
- Throttle lever (1)
- Metric allen key (3)

•Throttle pushrod (1)

- M2 short balls (7) (servo arms)
- M2 nut (7) (servo arms)
- 3x25 socket head cap screws (4)
- M3 locknut (4)

Fin pack:

- Vertical and horizontal fins (1ea.)
- tail rotor blades (2)
- 3x16 socket head cap screws (4)
- M3 locknut (6)
- 3x8 self tapping screws (2) (fin clamp underside)
- 3x8 flat washer (4)
- 3x9x4 thick spacer (2) (boom support to frame)
- 3x30 socket head cap screws (2) (vertical fin)

Landing gear:

- Landing struts (2)
- Landing skids (2)
- M3 locknut (4)
- 3x20 socket head cap screws (4)
- 3x9x4 plastic landing gear spacer (4)
- 3x4 set screw (4)

Canopy (1)

- Windshield (1)
- Decal sheet (1)
- Lower frame set (1)
- Servo frame set (1)
- Muffer (1)
- Main rotor blades (1 pair with hardware)

Section 1: Preparing the engine

Remove the thrust washer that comes on the engine from the factory. Only use the 9x14 washer that comes with the fan and clutch package. Mount that washer first and the clutch (1.1-1.2) to the engine using thread lock. Mount the fan so the two protruding portions on the underside slide into the slots machined in the clutch (1.3). Remove the stock engine throttle arm and use the one provided with the helicopter kit. (packed with the fuel hardware/pushrods pack). Place the 6.5x13 Washer (packed with fan and clutch also) between the fan and the crankshaft nut and tighten using thread lock (1.4). In order to tighten the assembly properly, the piston must not be allowed to turn (you can use the optional #CN2155 piston locking tool).

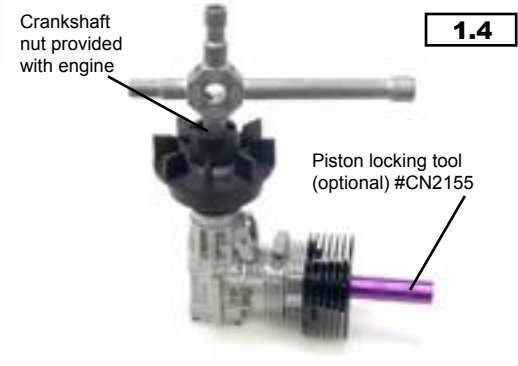
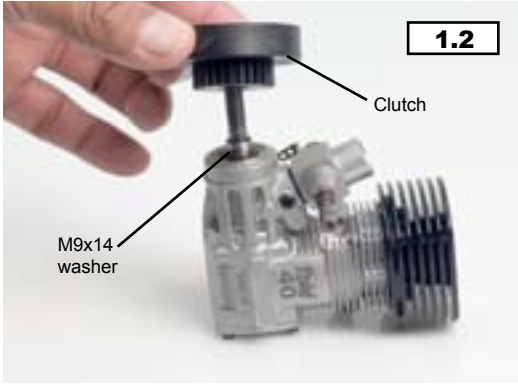
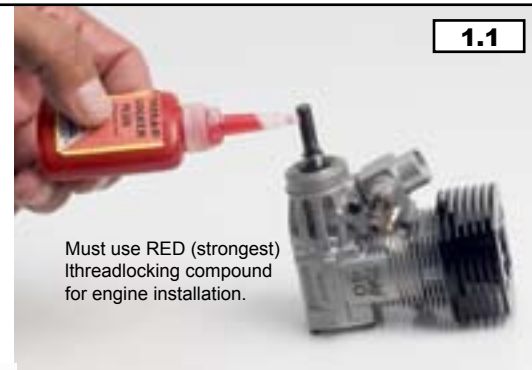

Section 2: Assembling the main frame

Using thread lock, mount the engine assembly to the engine mount in the lower side frame assembly (2.1). After the engine is installed, combine the upper and lower side frame sections (2.2). Before bolting, attach the fan shroud securely to the frame assembly slightly overlapping the fan shroud portion of the upper side frames (2.3). Use hardware provided to finish assembling the frames. (2.4 & 2.5). Install the canopy mounting hardware (2.6 & 2.7) by first threading one end of the threaded steel rod into one of the aluminum standoffs. Insert the aluminum standoff and rod into the frame (2.6) and thread the other standoff (2.7) on until tight. The upper and lower frames are now assembled (2.8).

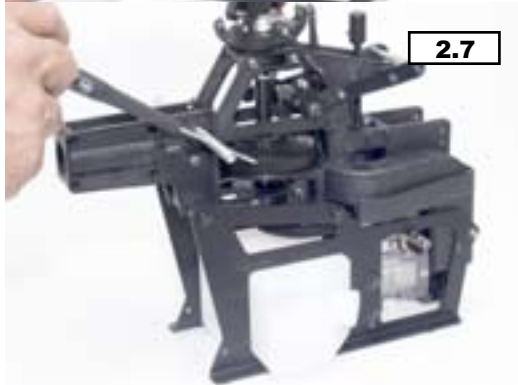
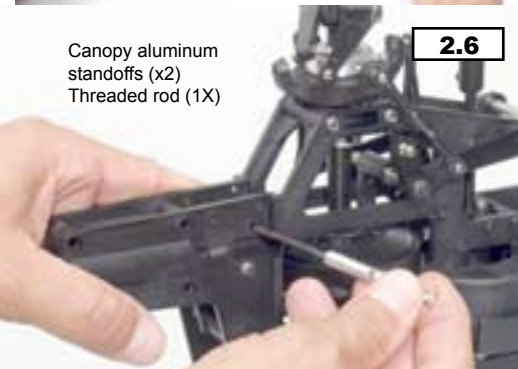
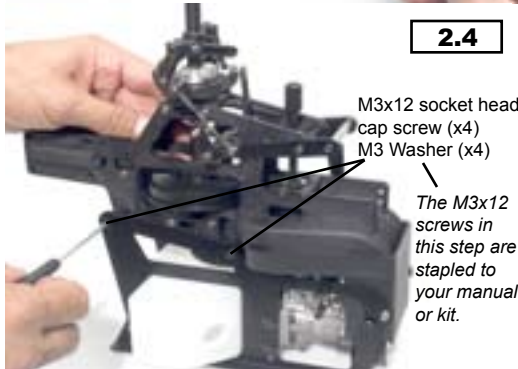

Section 3: Assembling the servo tray

Insert and attach the lower throttle servo on the left side (3.1) with the output "horn" facing the front of the servo tray. Install the upper collective servo above the throttle servo with the output facing the back (3.2). Attach the aileron servo (3.2) to the middle of the top portion of the servo tray with the horn facing forward. Attach the elevator servo to the left of the aileron servo horn facing rearward (3.2). Attach the power switch (3.3) to the switch plate provided on the right hand side of the servo frame. Slide the gyro in place (3.4). If possible, expose the gyro's manual controls for future easy adjustment. Attach the servo frame assembly to the main frame assembly forward section (3.5 - 3.6) using provided hardware. Attach the rear rudder servo mount to the right hand aft section of the upper side frame with the output facing rearward (3.7). Completed section (3.8) depicted.

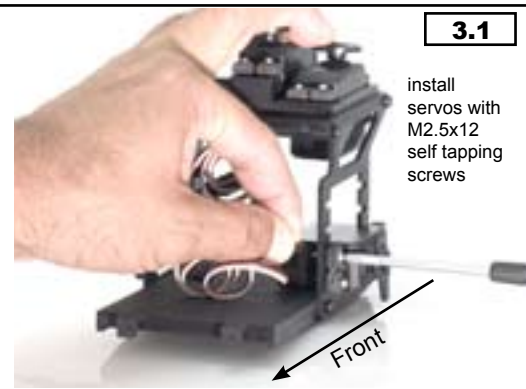

3.1

install servos with M2.5x12 self tapping screws

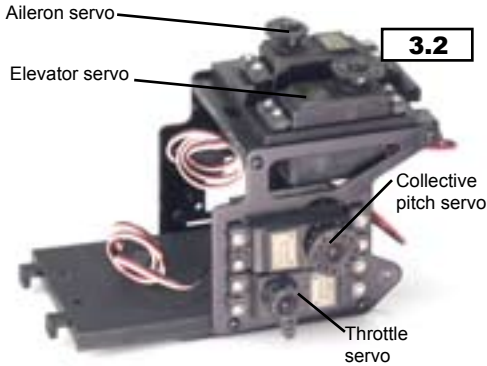

3.2

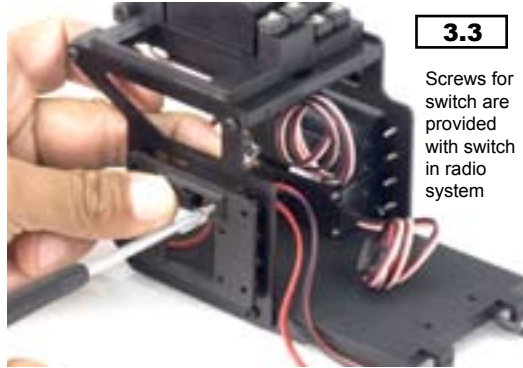

3.3

Screws for switch are provided with switch in radio system

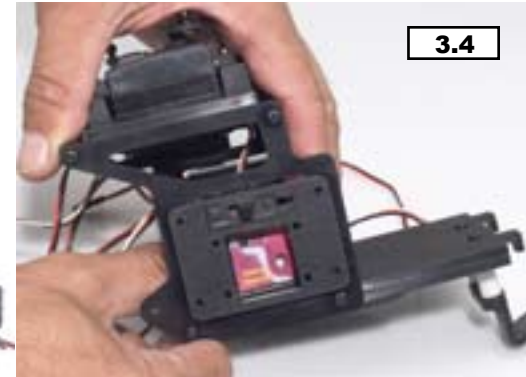

3.4

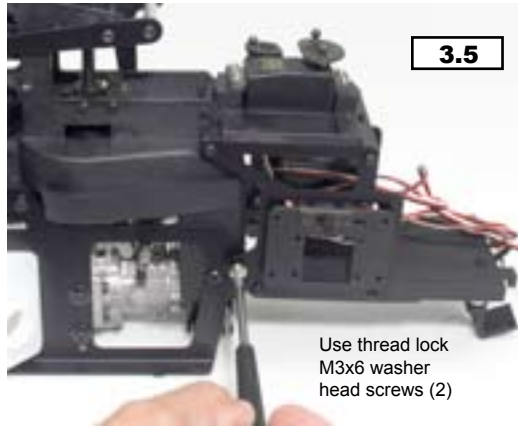

3.5

Use thread lock M3x6 washer head screws (2)



3.6

3x12 self tapping screws (2)

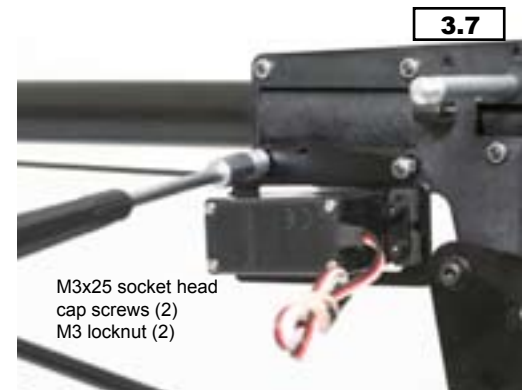

3.7

M3x25 socket head cap screws (2)
M3 locknut (2)



3.8

Section 4: Fuel tank & fittings

Assemble the fuel stopper (found in the bag with the upper frames) (4.1) by bending the longer aluminum tube (connects to muffler nipple) so it will end at the top inside the fuel tank. Align the short straight aluminum tube level to the engine carburetor fuel intake. Secure with M3x18 screw supplied in clutch/fan package and tie wrap (4.2 & 4.3)

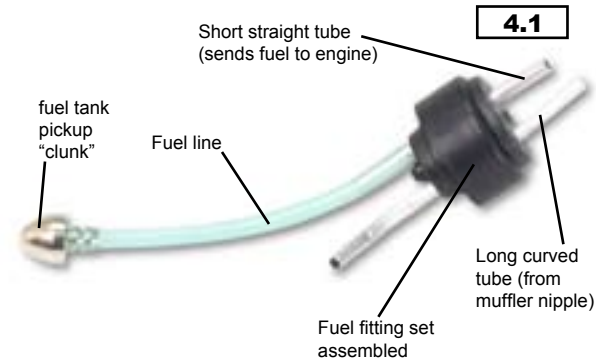

4.1



4.2

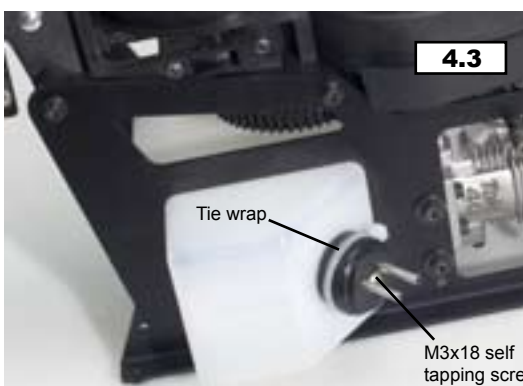

4.3

Tie wrap

M3x18 self tapping screw

Section 5: Muffler & fuel routing

Install the pressure nipple using a high temperature adhesive (thread lock) to the top of the muffler and the 4mm plug screw to the bottom (5.1). Bolt the muffler to the engine (5.2) flush (no gasket required) using thread lock. Connect fuel tube between the fuel pickup in the tank and the carb on the engine with as little slack as possible (5.3). Connection between the carb and the fuel pickup tube (short straight) should be level (keeps fuel draw rate in inverted flight). Connect the fuel tank air tube (long curved) to the muffler pressure nipple (5.3).

5.1

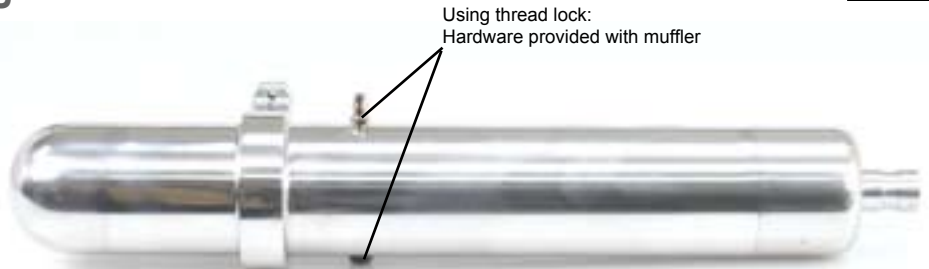

(Optional Toki muffler for Toki .40 engine shown. Toki muffler is supplied with a Hawk Pro "Toki engine and muffler combo")

Using thread lock:
3x25 socket head cap screw (2)

5.2



5.3



5.4



Section 6: Flybar & head assembly

Install the flybar, flybar control arms, weights and paddles into the rotor head seesaw assembly as shown (6.1). First slide the flybar in place through the seesaw assembly. Then slide the ball bearings into the seesaw cups on each end. Then slide the M3x6 plastic spacers on to each side of the flybar. Next slide the 2 flybar control arms as shown (6.1) Use thread lock on the set screws connecting the flybar weights to the flybar (6.2 - 6.3). Align the flybar paddles and control arms level to the seesaw assembly (LEADING EDGE OF PADDLES MUST GO CLOCKWISE). The assembled flybar must be the same length on each side of the rotor head. Install the completed rotor head to the main shaft (6.4) with one 3x16 cap screw and M3 locknut.

6.1

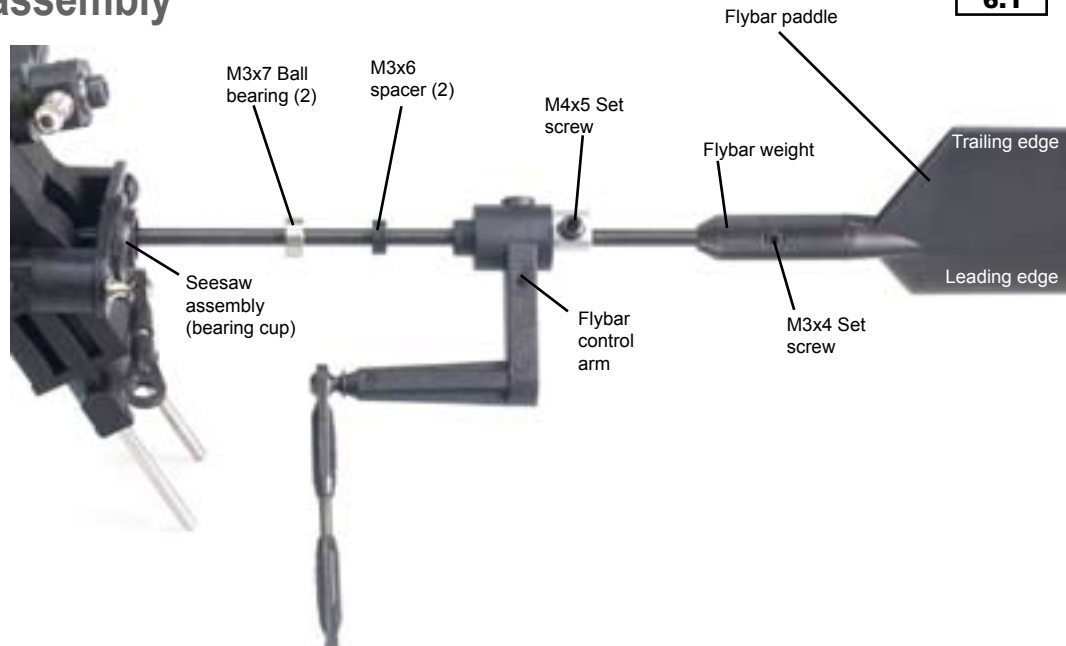

6.2

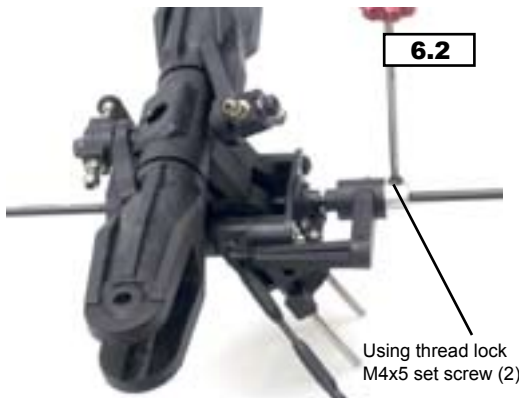

6.3

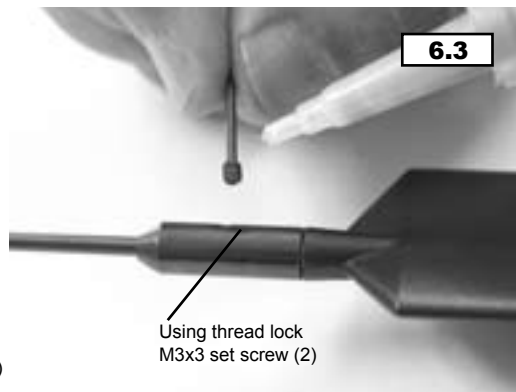

6.4

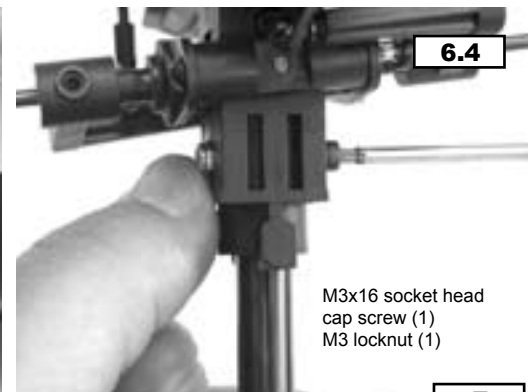

7

Section 7: Landing gear

All components for installing landing gear are included with the landing gear bag. Attach the plastic U shaped struts to the bottom of the main frame and insert the metal skids when aligned (7.1). Bolt the landing gear to the main frame using provided hardware (7.2). Attach the skids only when helicopter will sit level using the provided set screws and CA glue (7.3). At the end of this section the helicopter should be able to stand upright (7.4).



7.1

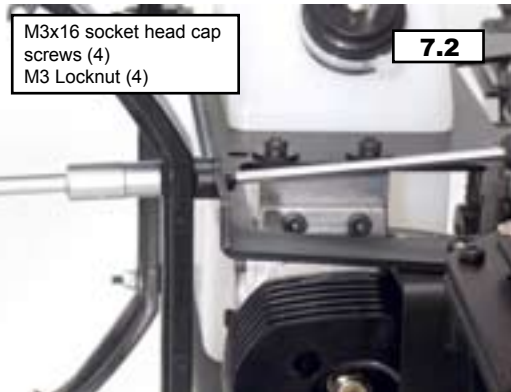

M3x16 socket head cap screws (4)
M3 Locknut (4)

7.2

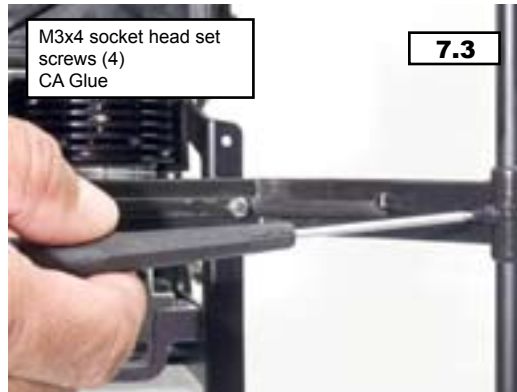

M3x4 socket head set screws (4)
CA Glue

7.3



7.4

Section 8: Tail boom & drive system

The tail section (8.1) is completely assembled and only requires to be attached to the main frame (use a small amount of gear grease inside the tail gearbox). Slide the tail boom into the aft section of the main frame with the tail rotor on the right side of the helicopter (8.2) twisting slightly until the notches in the tail boom align with the standoffs on the inside of the main frame. Once installed, the drive system should be complete and the main/tail blades should rotate when the main gear is turned. Attach the tail blades to the tail blade grips (8.3) using the hardware provided.

8.1

Remove the 3 socket head cap screws to open the gearbox in order to grease the gears.



Note:

Place a small dab of gear grease (synthetic hydrogen grease) between the two plastic gears.

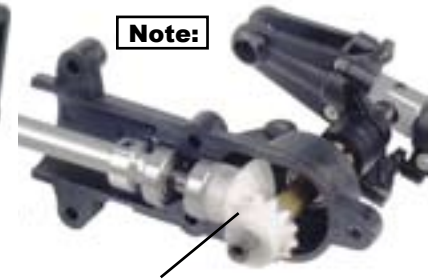

White coupler located inside the upper frames

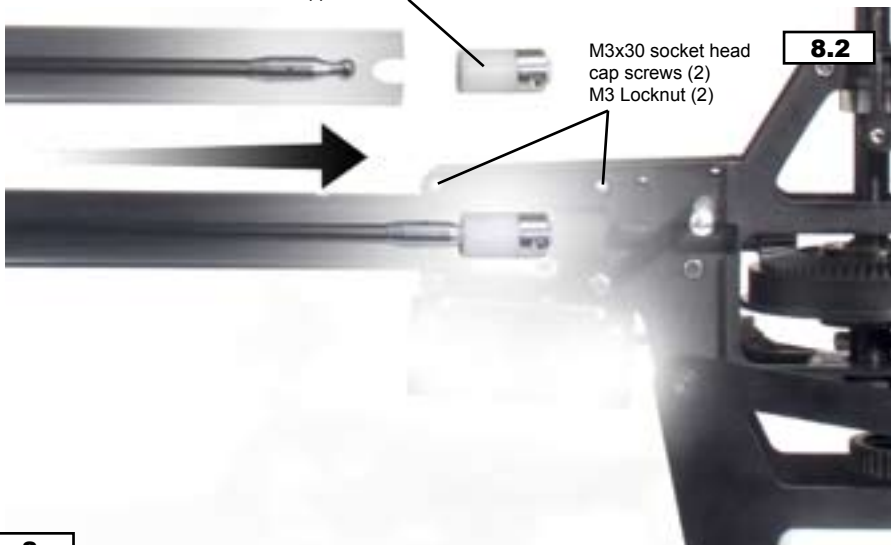

M3x30 socket head cap screws (2)
M3 Locknut (2)

8.2

8.3

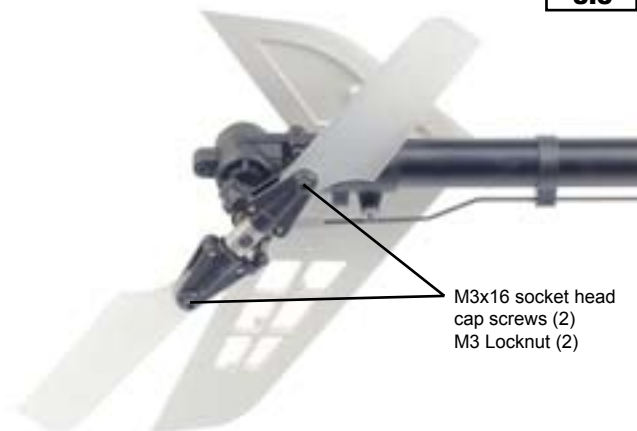

M3x16 socket head cap screws (2)
M3 Locknut (2)

Section 9: Tail boom supports & tail fin set

Attach the tail boom support struts to the base of the side frames using the plastic spacer on the outside of the frame (9.1). Attach the horizontal fin (hardware found inside fin bag) and tail boom supports onto the horizontal boom clamp (9.2) use the white plastic piece found with the canopy grommets between the fin clamp and the fin). Screws are provided for mounting the vertical fin in the package containing the fins (9.3).

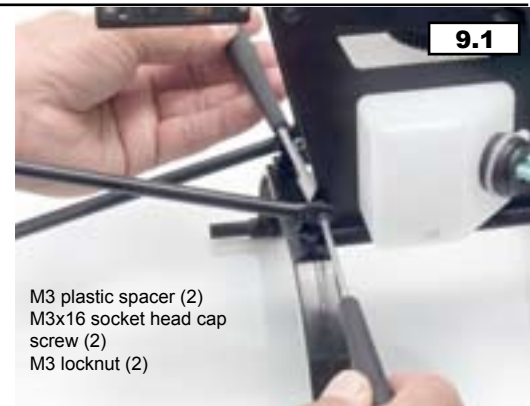

M3 plastic spacer (2)
M3x16 socket head cap screw (2)
M3 locknut (2)

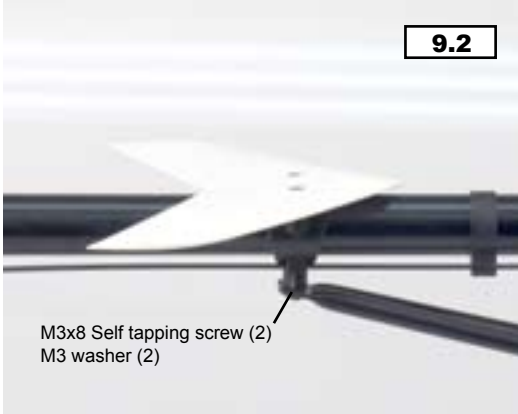

M3x8 Self tapping screw (2)
M3 washer (2)

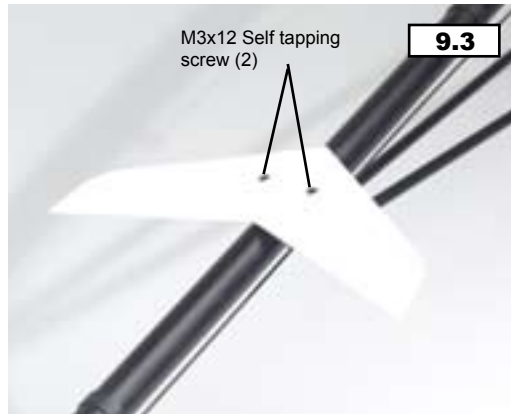

M3x12 Self tapping screw (2)



M3x20 socket head cap screw (2)
M3 locknut (2)

Section 10: Tail control rod & pitch control

Use the radio to center the rudder servo. Mount the servo arm/horn perpendicular to the tail pitch control rod threading the forward tail control rod ball link (found in the upper frame bag) onto the pushrod (10.1). Adjust link at rear of tail system so that the tail pitch slider is roughly centered on the tail output shaft (10.2). Connect the ball links to the control balls at either end only when the rudder servo is centered and the pitch slider is centered. Align the tail pushrod guides to help keep the pushrod traveling without flex (10.3). Fix the favorable positions of the pushrod guides (use CA glue) to avoid shifting/binding. Pushrod should travel through the horizontal fin clamp on the right side (10.2 & 10.4).

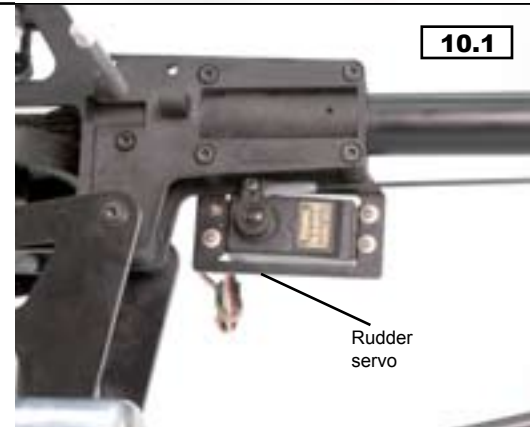

Rudder servo



10.2

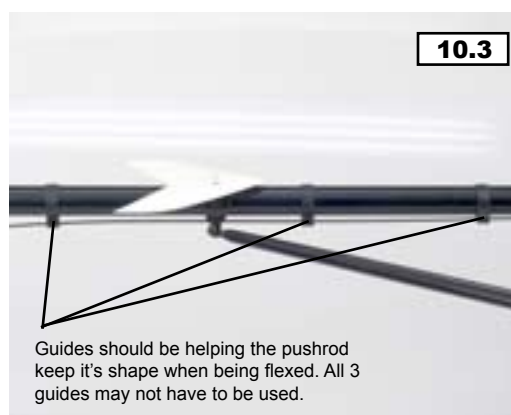

10.3

Guides should be helping the pushrod keep it's shape when being flexed. All 3 guides may not have to be used.

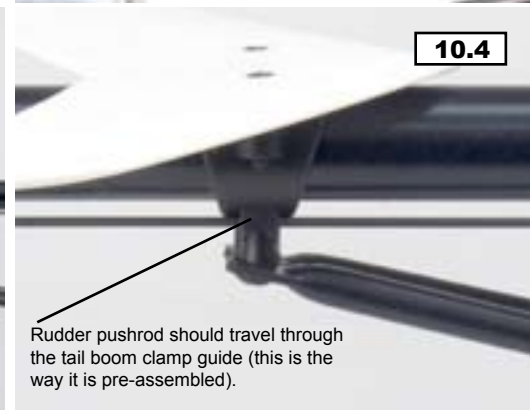

10.4

Rudder pushrod should travel through the tail boom clamp guide (this is the way it is pre-assembled).

Section 11: Throttle & Collective linkage

*Pushrod measurements include ball links from plastic end to plastic end. Before any pushrod adjustments are made center both sticks and all servos on the transmitter. Attach the 103mm throttle control rod to the throttle servo and the throttle arm on the carburetor. Be sure that when the throttle collective stick is in the middle, that the throttle servo arm is straight up, and that the carburetor barrel is half open and its control arm is also pointed straight up. Adjust the collective control rod to 102mm for training or to 100mm for 3D. Attach this rod to the collective control lever and collective servo. Be sure the collective servo wheel is attached so that at mid stick it is pointed straight up.



Collective pitch servo

Throttle servo

Section 12: Cyclic servo linkage

Before any pushrod adjustments are made center both sticks and servos on the transmitter.

*Pushrod measurements include ball links from plastic end to plastic end. Adjust the two aileron control rods to 158mm and attach the two balls on the aileron servo wheel and to the two aileron bellcranks. Adjust the elevator control rod to 135mm and attach to the elevator servo arm and elevator bellcrank.

Aileron servo

Elevator servo

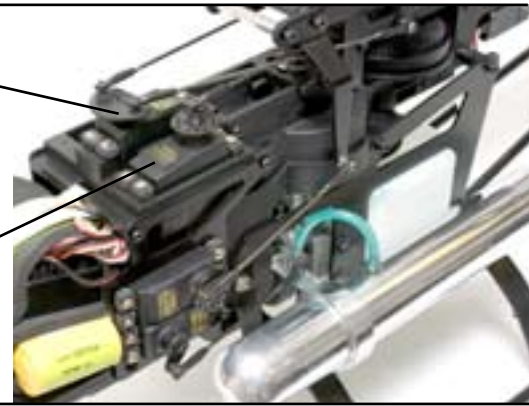

Section 13: Rotor head linkage

Before any pushrod adjustments are made center both sticks and servos on the transmitter.

*Pushrod measurements include ball links from plastic end to plastic end. Attach the two 106mm pushrods (shorten to 104mm for training) to the short balls on the washplate and to the short balls on the bell mixers on the main rotor blade grips. NOTE: For faster cyclic response in 3D you may want to change the bell/hiller ratio by moving the A-arms from the washout assembly to the short balls on the inner star of the swashplate and attach these 106mm rods to the longer balls on the inner star.



Section 14: Connect the electronics

Plug in the switch, servos and gyro to the radio receiver. Wrap the receiver and the battery pack with the proper foam protection recommended by your radio manufacturer and secure to the top of the battery/receiver platform at the lower front of the servo tray (use #64 rubber bands).



Section 15: Main rotor blade installation

Each rotor blade has 3 holes drilled in the root. Use epoxy to glue the plastic root ends to the exposed wood pre-cut by the factory (15.1). Use the countersunk screws (15.2) to secure the root ends to the blades and let the glue dry. Use the 2 M4x30 blade bolts and M4 locknuts to secure the blades to the blade grips on the main rotor head (15.3). Main rotor blades should have their leading edge turning clockwise.

15.1

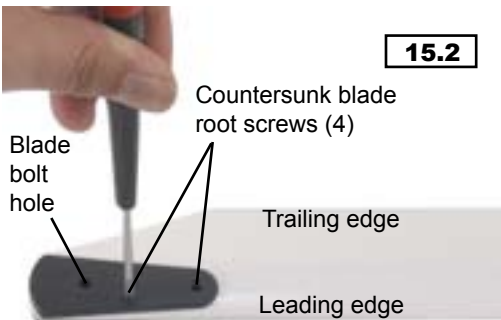

Section 16: Antenna routing

Thread the small clear tube into the guides (located on the right bottom side of the struts) on the side opposite the muffler. Insert the receiver antenna into the tube and secure to the rear area of the tail boom or one of the boom support struts. It is recommended that you use a small rubber band to do so.



Section 17: Mounting the canopy

Carefully cut out the windshield area from the canopy (17.1) with a sharp hobby knife. Trial fit the canopy and mark the location of the front lower mount (17.2), drill the two required holes and attach to the inside of the canopy with the screws and washers provided. Mount the front of the canopy (17.3) and mark the location of the top rear mounts. Drill the 1/4 " holes and insert the grommets (17.4). Cut out the windshield along the marked lines (17.5) and install onto the canopy with the six small screws supplied. Cut out the decals for the canopy from the decal sheet and attach to the canopy (17.6) Then mount the canopy on the helicopter.

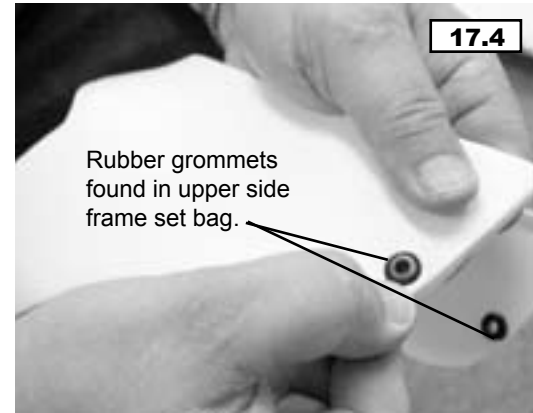
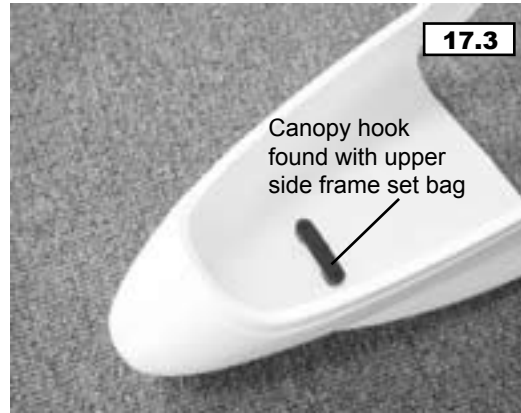
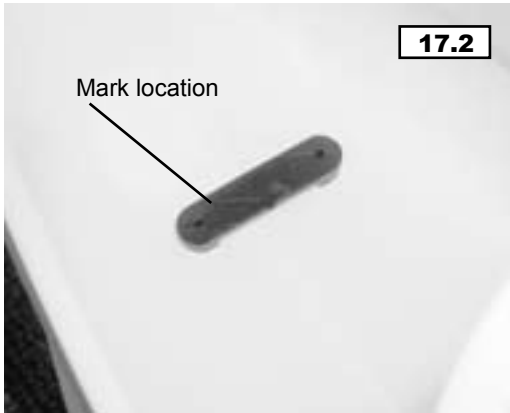
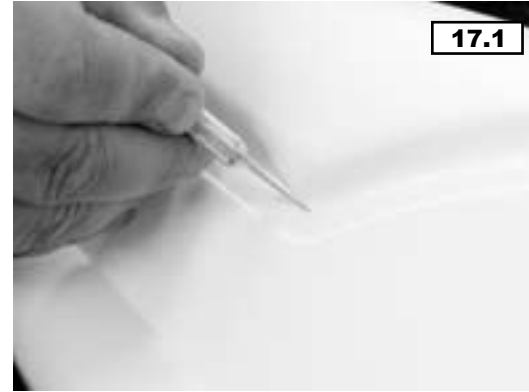

The completed model

Your helicopter is assembled, your engine, servos, gyro and receiver installations are complete. Now you will have to refer to your engine manual for starting and running instructions, your gyro manual for set-up instructions and your radio manual for the transmitter set-up instructions.



Main Sub-Assemblies

This section will overview parts that came pre assembled from the factory. Items not attached to main sub assemblies can be found in the parts list.

Main Rotor Head

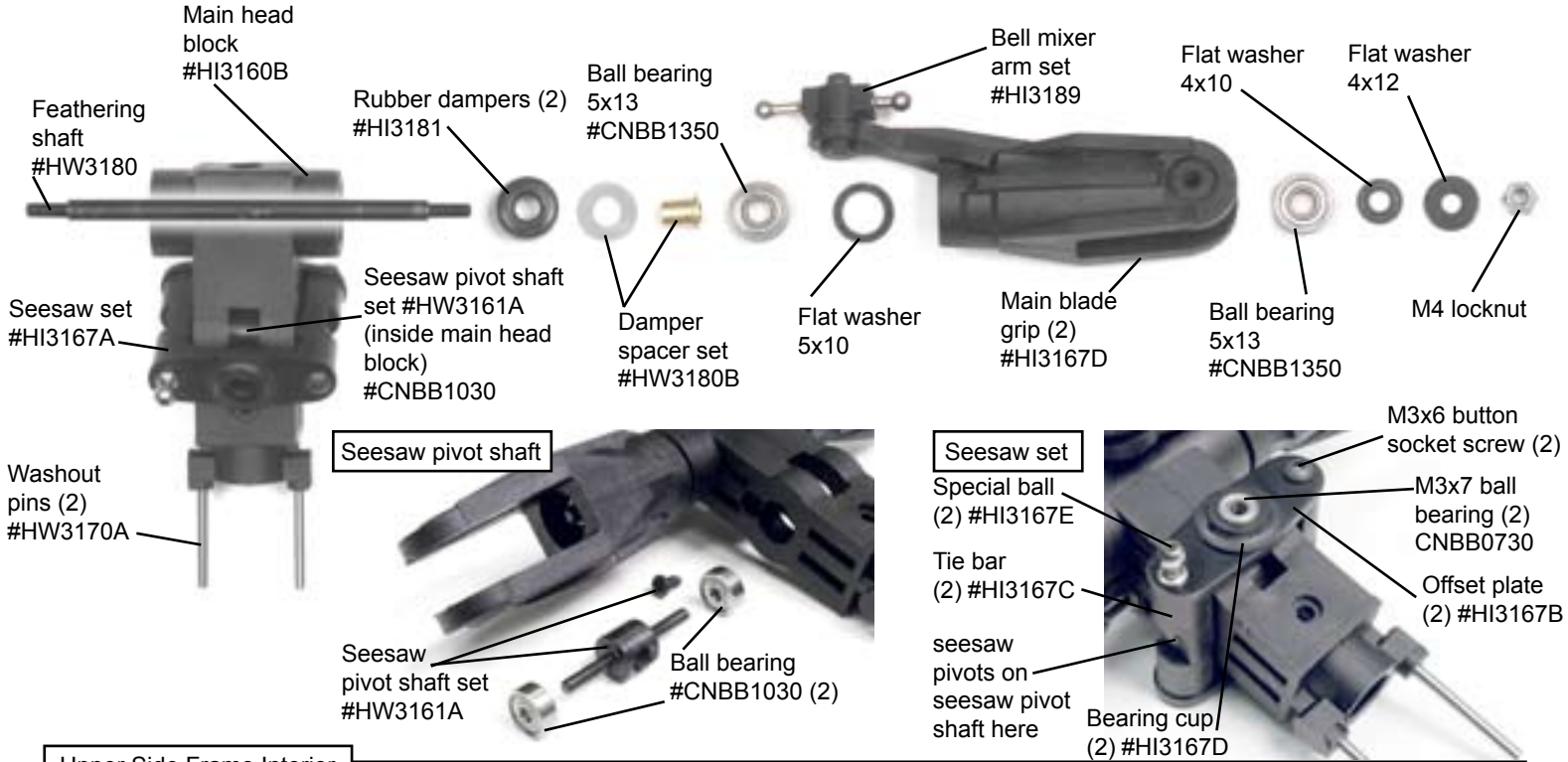

Upper Side Frame Interior

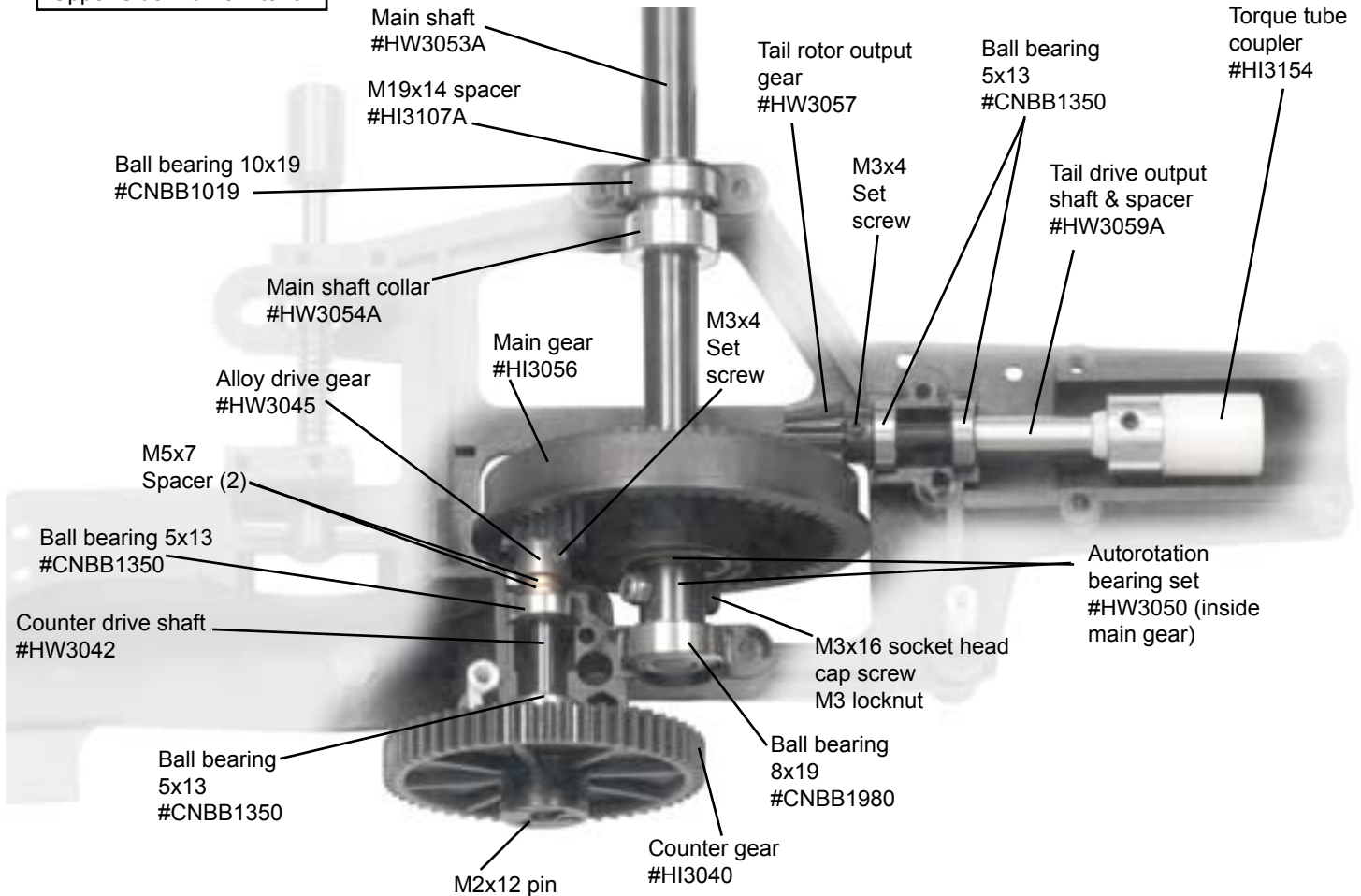

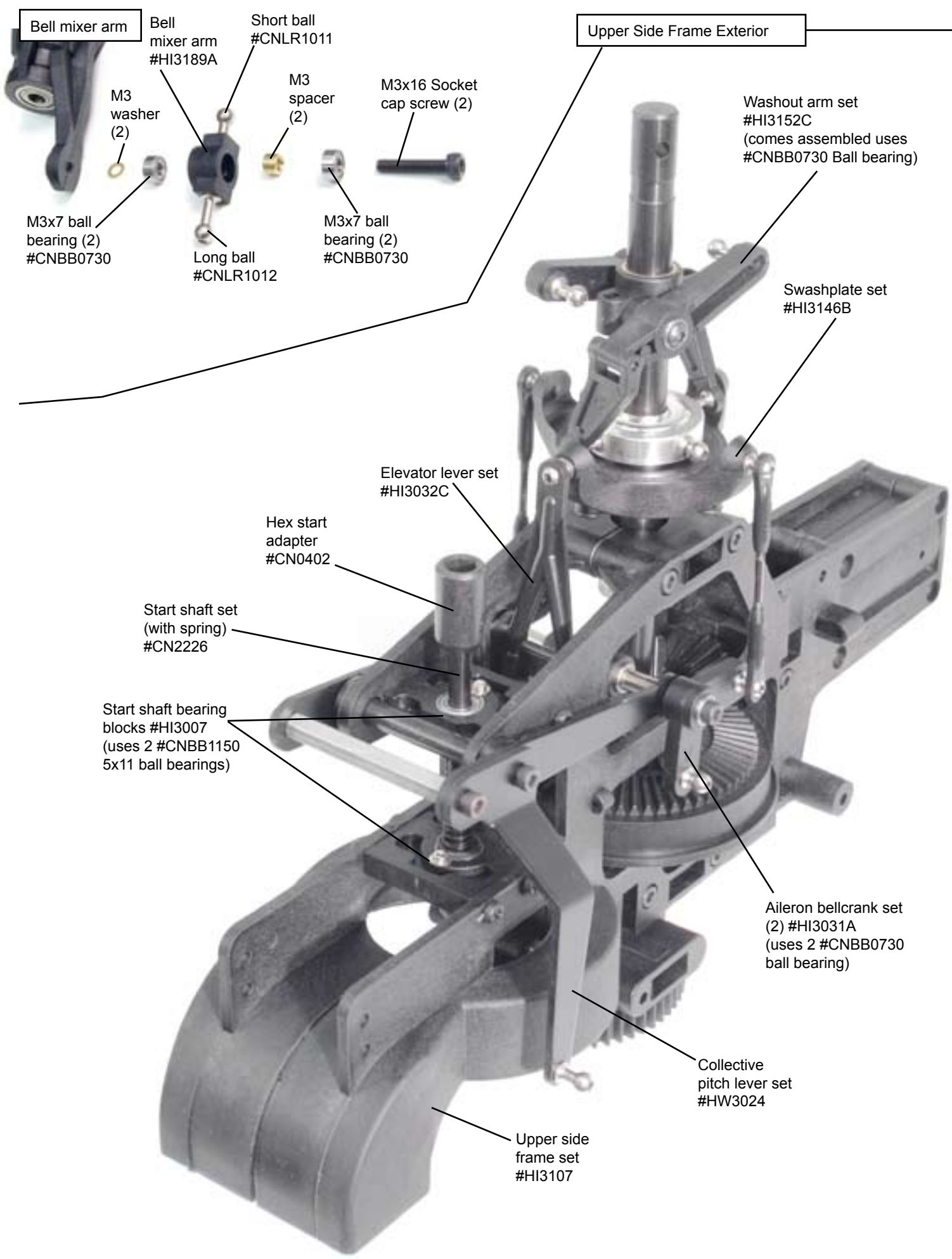

Bell mixer arm

Bell mixer arm #HI3189A

Short ball #CNLR1011

Upper Side Frame Exterior

M3 washer (2)

M3 spacer (2)

M3x16 Socket cap screw (2)

Washout arm set #HI3152C (comes assembled uses #CNBB0730 Ball bearing)

M3x7 ball bearing (2) #CNBB0730

Long ball #CNLR1012

M3x7 ball bearing (2) #CNBB0730

Swashplate set #HI3146B

Elevator lever set #HI3032C

Hex start adapter #CN0402

Start shaft set (with spring) #CN2226

Start shaft bearing blocks #HI3007 (uses 2 #CNBB1150 5x11 ball bearings)

Aileron bellcrank set (2) #HI3031A (uses 2 #CNBB0730 ball bearing)

Collective pitch lever set #HW3024

Upper side frame set #HI3107

Collective pitch lever

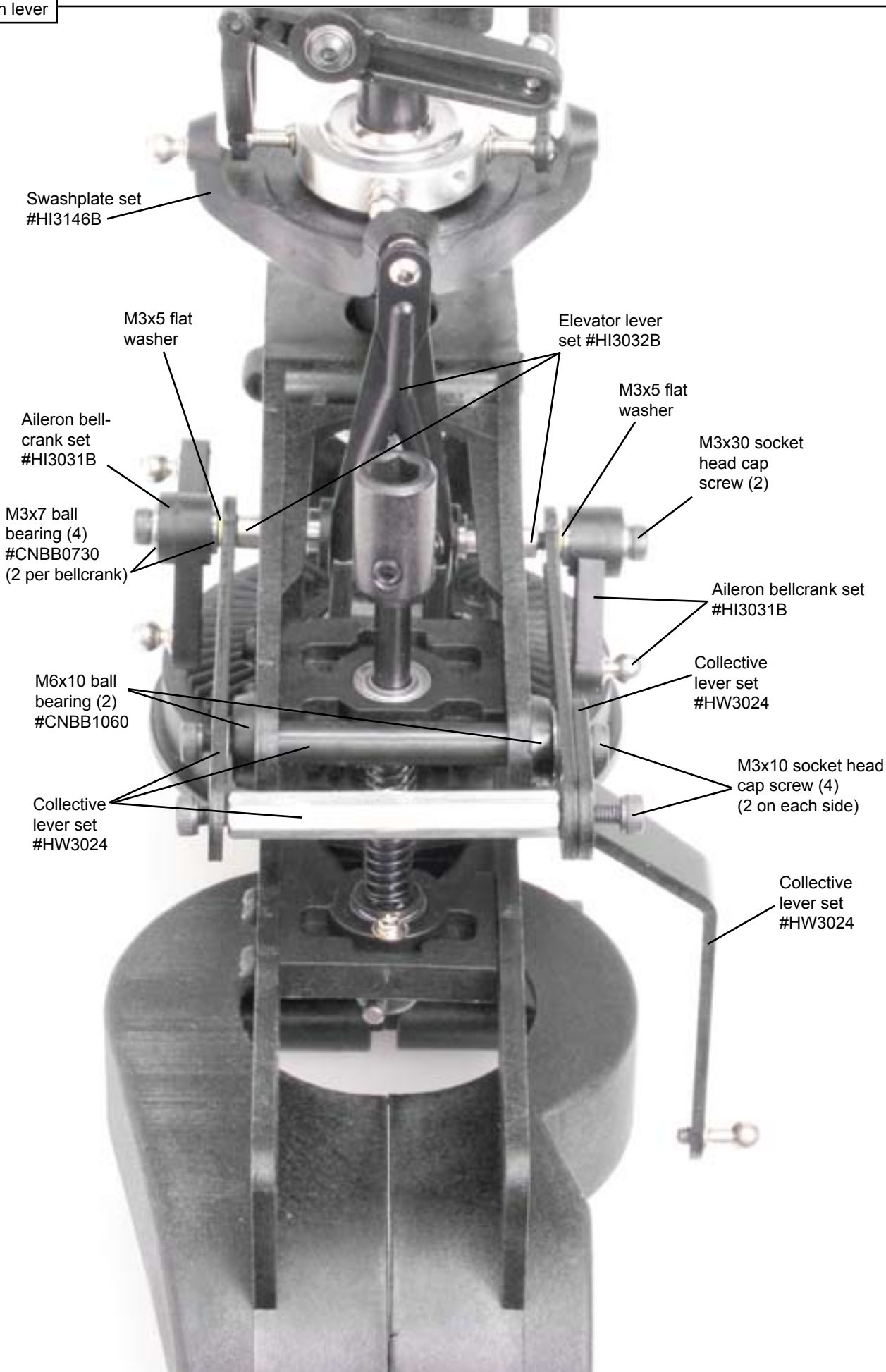

Swashplate set
#HI3146B

M3x5 flat
washer

Aileron bell-
crank set
#HI3031B

M3x7 ball
bearing (4)
#CNBB0730
(2 per bellcrank)

M6x10 ball
bearing (2)
#CNBB1060

Collective
lever set
#HW3024

Elevator lever
set #HI3032B

M3x5 flat
washer

M3x30 socket
head cap
screw (2)

Aileron bellcrank set
#HI3031B

Collective
lever set
#HW3024

M3x10 socket head
cap screw (4)
(2 on each side)

Collective
lever set
#HW3024

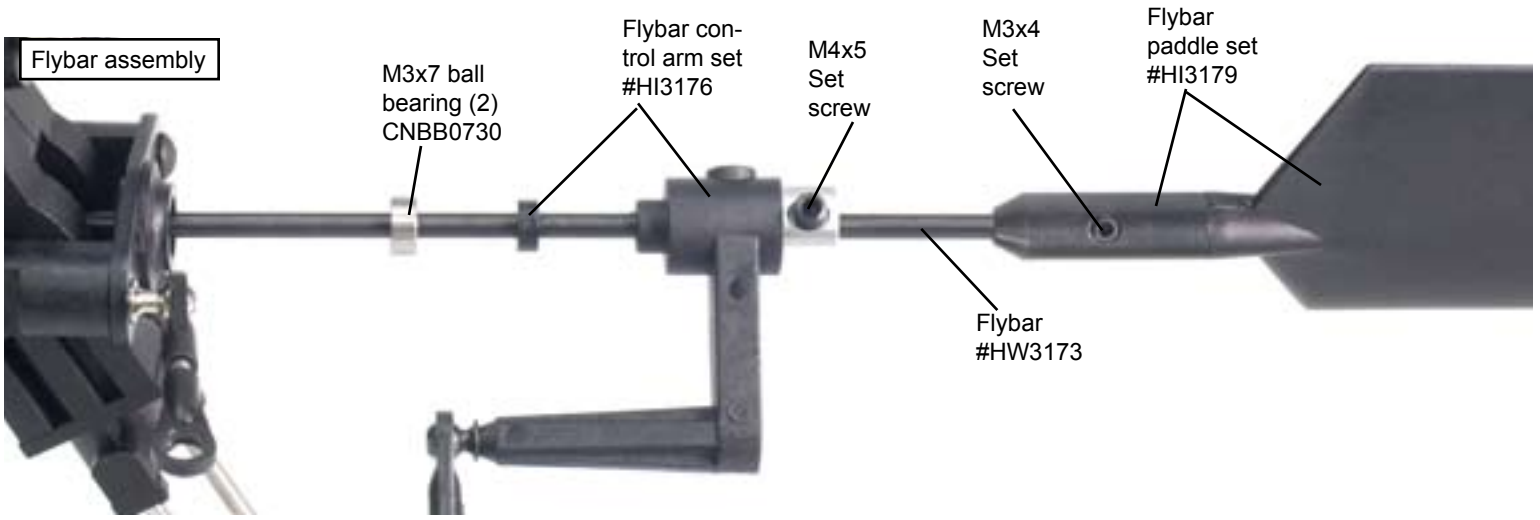

Main gear



Starter shaft

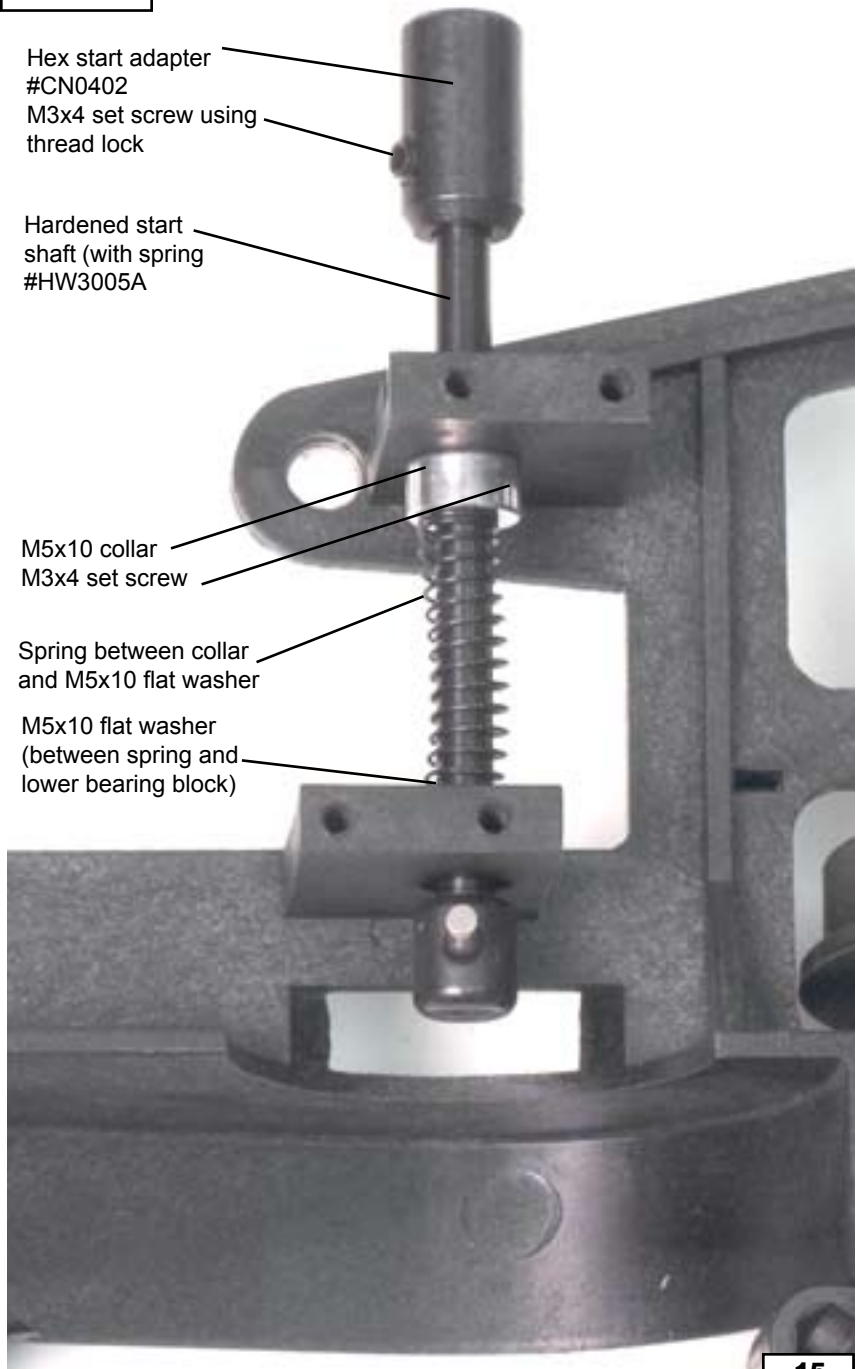

Lower Side Frames

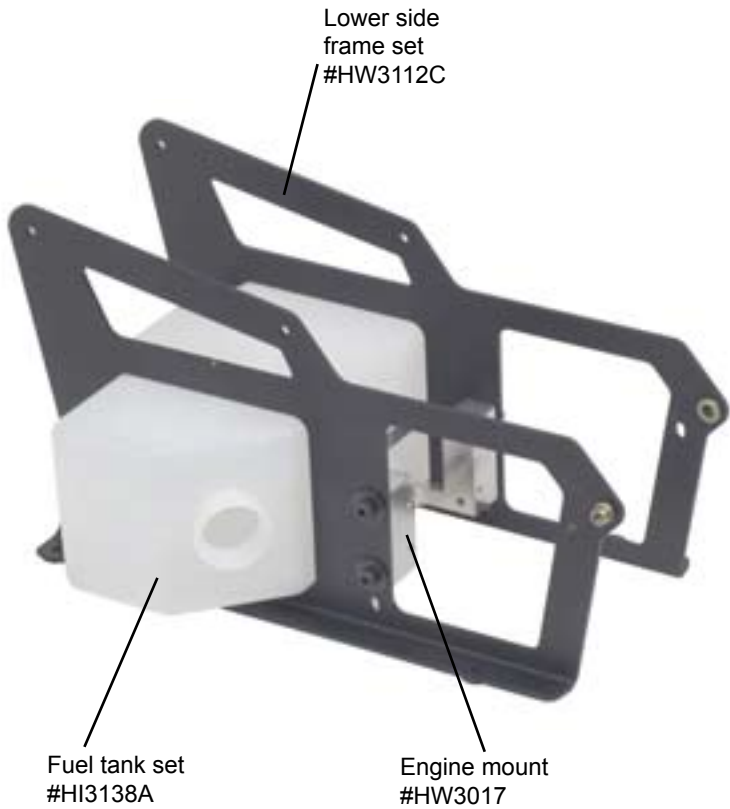

Servo Side Frame Set

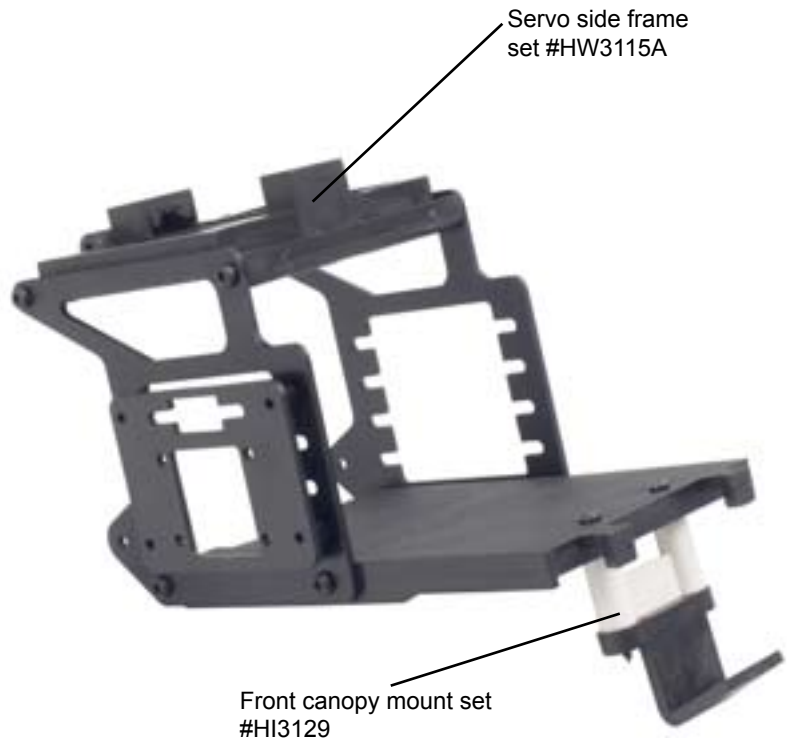

Tail Section Interior

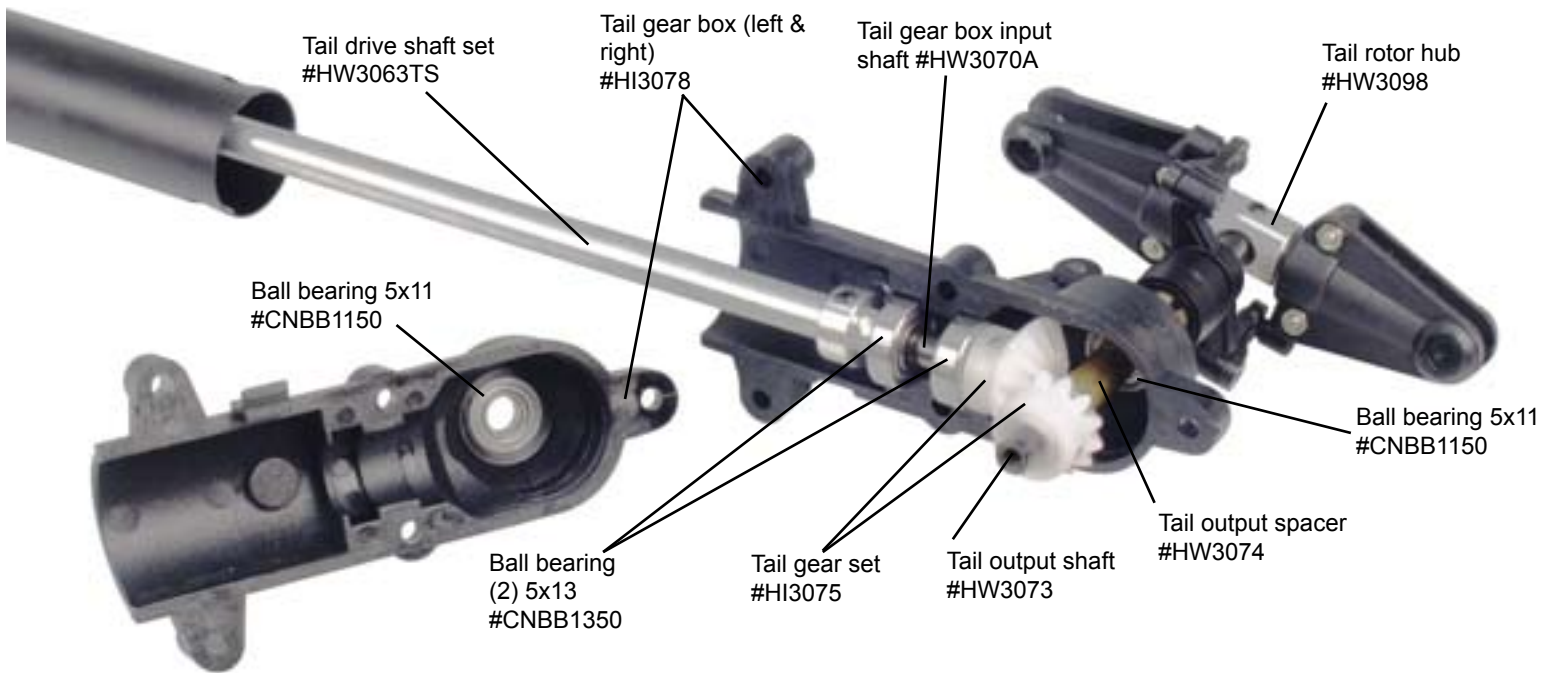

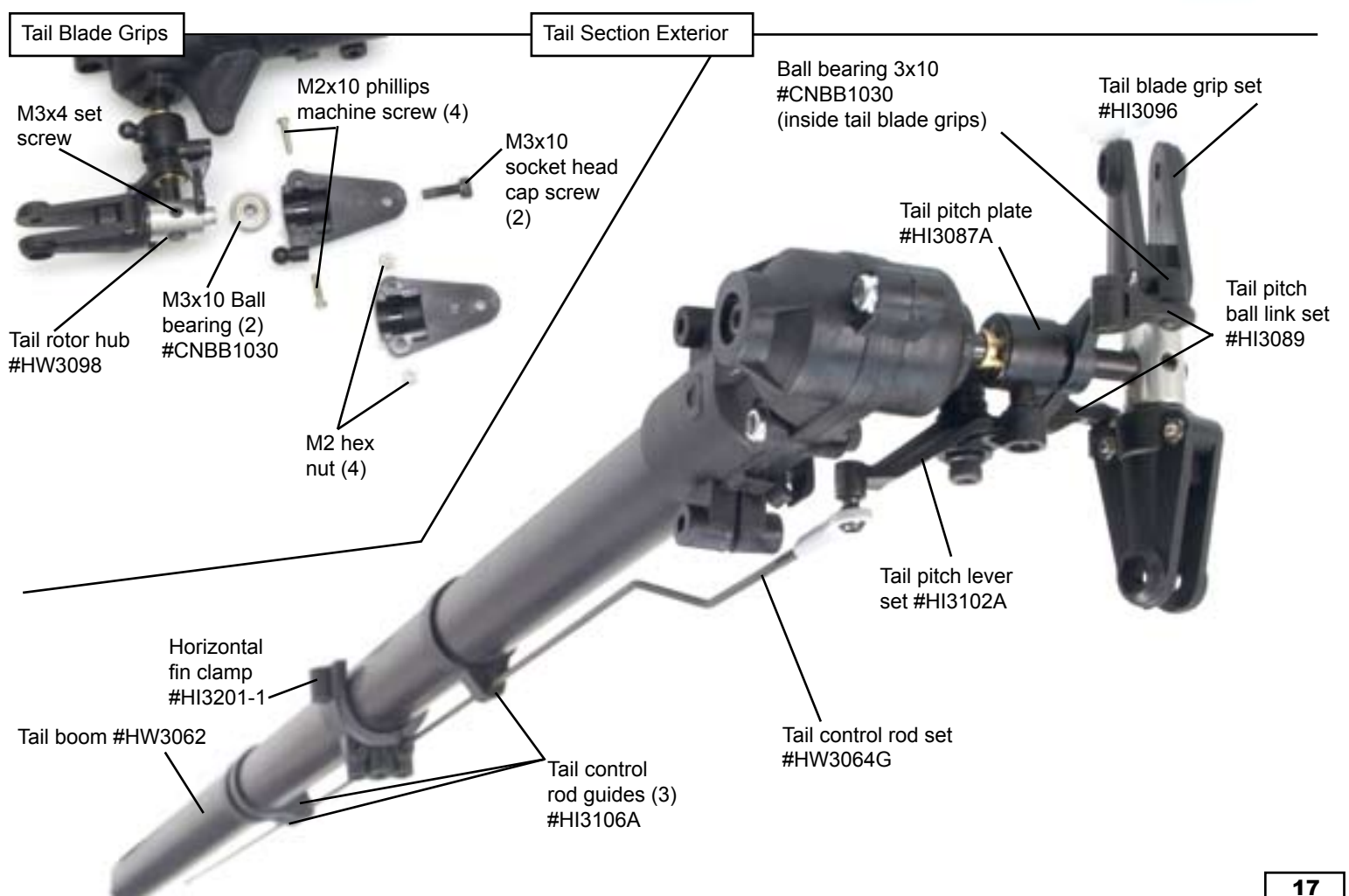
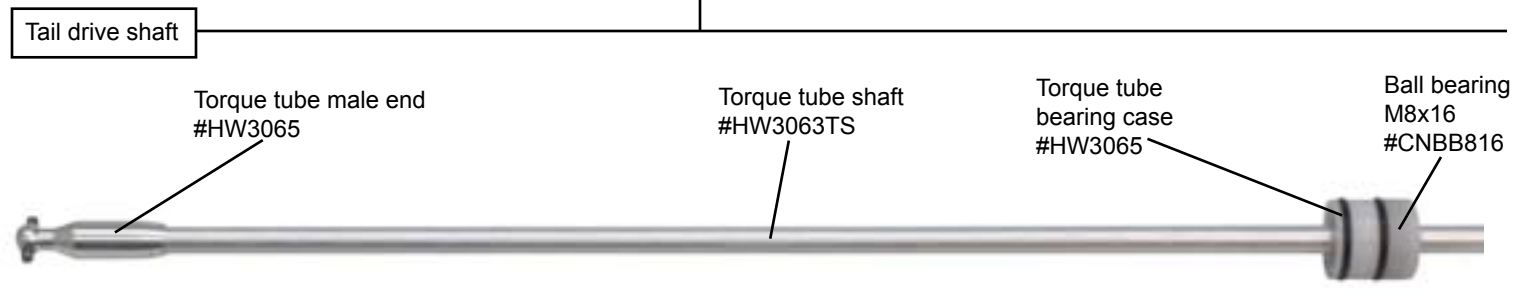
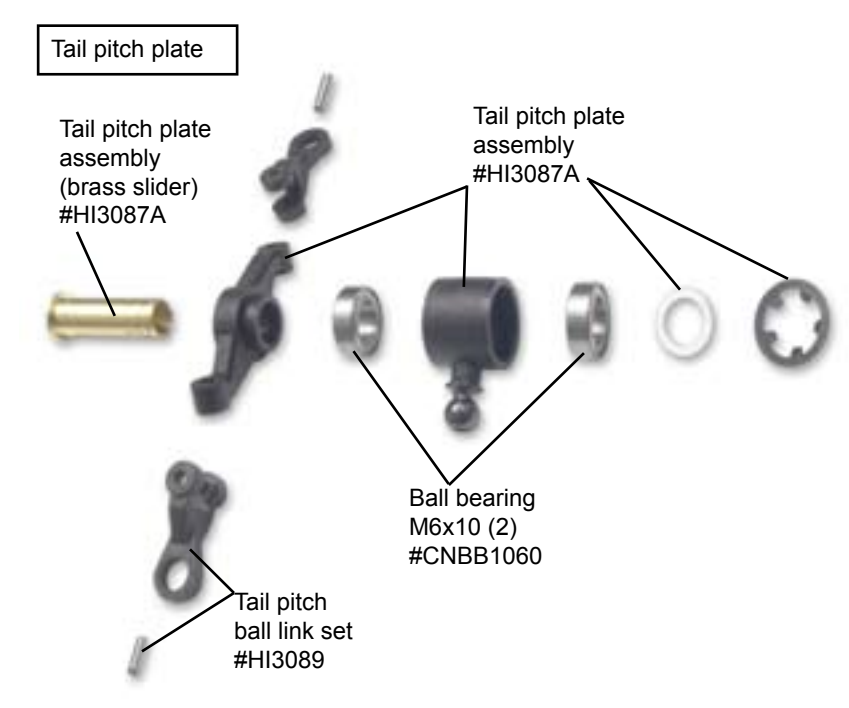
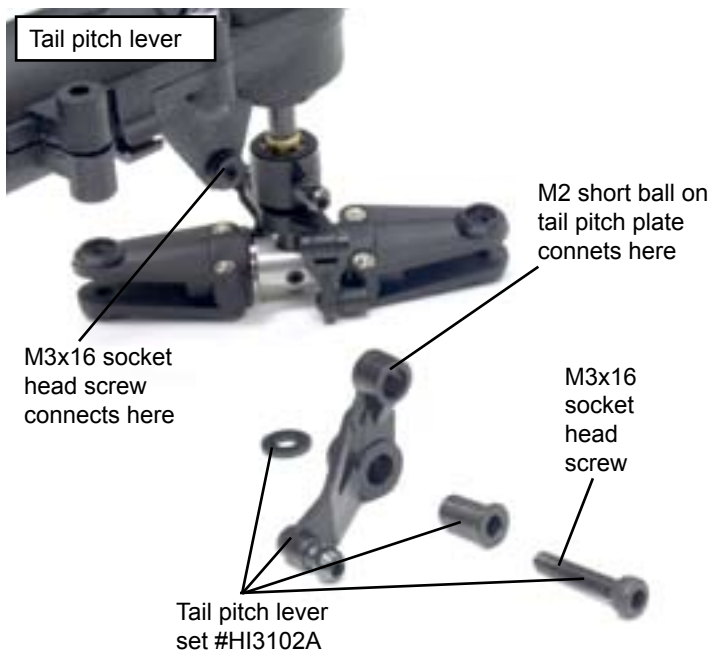

Hawk Pro Replacement Parts

CN2230H4	CRASH KIT -(Main Blades, Main Shaft, Tail Boom, Feathering Shaft and Flybar)	1	HI3122	LANDING STRUTS (PLASTIC)	2
HW3000	HARDWARE PACK	1	HW3123	LANDING SKIDS (METAL)	2
CN0402	HEX START COUPLER	1	HW3127A	HEX SPACER & CANOPY MOUNT SET	1
HW3005A	STARTER SHAFT SET	1	HI3129	CANOPY MOUNT & HARDWARE	1
HI3007	STARTER SHAFT BEARING BLOCKS	1	HI3130B	CANOPY	1
HI3009	COOLING FAN	1	HI3131M	HAWK PRO DECAL SET	1
HI3010	CLUTCH BELL & LINING	1	HI3133A	CLEAR WINDSHIELD (for HI3130B)	1
HW3011	CLUTCH SHOES	1	HI3138A	FUEL TANK	1
HW3017	ENGINE MOUNT	1	HI3145	BALL LINKS (16 LONG & 6 SHORT)	1
HI3020	COOLING FAN SHROUD	1	HI3146B	SWASHPLATE WITH STEEL BALL END	1
HW3024	COLLECTIVE PITCH LEVER SET	1	HI3152C	WASHOUT SET	1
HI3031A	AILERON BELLCRANKS (L&R CYCLIC)	2	HI3152A	RADIUS LINK WITH PIN	2
HI3032B	ELEVATOR LEVER SET (LONG)	1	HI3160B	ROTOR HEAD BLOCK	1
HI3032C	ELEVATOR LEVER ONLY (LONG)	1	HW3161A	FLYBAR SEESAW SHAFT SET	1
HI3035A	ADJUSTABLE CYCLIC PUSHROD LINKS	2	HI3167A	FLYBAR SEESAW COMPLETE SET	1
HI3040	COUNTER DRIVE GEAR	1	HI3167B	SEESAW OFF SET PLATE	2
HW3042	PRIMARY DRIVE SHAFT	1	HI3167C	SEESAW TIE BAR	2
HW3045	ALLOY DRIVE GEAR 13T	1	HI3167D	SEESAW BEARING CUP	2
HW3050	AUTOROTATION BEARING SET	1	HI3167E	SPECIAL BALL M3X6	2
HW3053A	10mm MAIN SHAFT	1	HW3170A	WASHOUT PINS	2
HW3054A	10mm MAIN SHAFT LOCK RING	1	HW3173	FLYBAR	1
HI3056	MAIN GEAR	1	HI3176	STABILIZER CONTROL ARM	2
HW3057	TAIL DRIVE BEVEL GEAR	1	HI3179	FLYBAR PADDLES	2
HW3059A	TAIL DRIVE PRIMARY SHAFT	1	HW3180C	FEATHERING SHAFT	1
HW3062	TAIL BOOM	1	HW3180B	DAMPENER SPACER SET	2
HW3063TS	TAIL DRIVE SHAFT SET	1	HI3181	DAMPING RUBBERS	2
HW3064G	TAIL PITCH CONTROL ROD	1	HI3184	ROTOR BLADE GRIP	2
HW3065	TORQUE TUBE MALE END WITH COLLAR	1	HI3189	MIXING ARM SET	1
HW3065A	TORQUE TUBE BRG. HOLDER WITH O-RING	1	CN2322	MAIN ROTOR BLADES (PAIR)	1
HI3067A	TAIL FIN SET	1	HW3192	LINKAGE SET (11 RODS)	1
HW3070A	TAIL GEARBOX INPUT SHAFT	1	HW3202B	T/B SUPPORT STRUTS (PAIR)	1
HW3073	TAIL GEARBOX OUTPUT SHAFT	1	HW3204	THROTTLE EXTENSION	1
HW3074	TAIL GEARBOX SPACER TUBE	1	CNBB0730	Bearings 3X7X3 (Flybar,Elevator Lever)	2
HI3075	TAIL GEAR SET	1	CNBB1019	Bearings 10X19X6 (Top Main Shaft)	2
HI3078	TAIL GEARBOX L&R	1	CNBB1030	Bearings 3X10X4 (Seesaw,Tail Grips)	2
HI3087A	TAIL PITCH SLIDER SET	1	CNBB1060	Bearings 6X10X3 (Collective Axle, Pitch Plate)	2
HI3089	TAIL PITCH BALL LINKS	2	CNBB1150	Bearings 5X11X4 (Start Shaft,Tail Shaft)	2
HI3096	TAIL BLADE GRIP SET	1	CNBB1350	Bearings 5X13X4 (Counter shaft,Blade grips)	2
HW3098	TAIL ROTOR HUB	1	CNBB1150	Bearings 5X11X4 (Start Shaft, Tail Shaft)	2
HI3099	TAIL ROTOR BLADES (PAIR)	1	CNBB1980	Bearings 8X19X6 (BottomMain Shaft)	2
HI3102A	TAIL PITCH LEVER SET	1	CNBB1218	Bearing 12x18x4 (Clutch Bell)	1
HI3106A	TAIL CONTROL ROD CLAMPS	3	HW3050	Autorotation Bearing 12X18X16	1
HI3107	UPPER SIDE FRAMES	2	CNLR1014	Stainless M3 Ball joint with short standoff	2
HI3107A	10mm BEARING SPACER 14x19x1	2	CNLR1015	Stainless M3 Ball joint with medium standoff	2
HW3112C	LOWER SIDE FRAMES	2	CNLR1016A	Stainless M3 Ball joint with long standoff	2
HW3115A	SERVO MOUNT FRAME SET	2	CNLR1013	M2 Ball joint with short standoff	2
			CN3033A	Black Torpedo Muffler 32-40	1

Hawk Pro Upgrade Parts & Accessories

CN0427	Hex start wand with one-way bearing		CN2208B	Metal Swashplate Anti-rotation Bracket - black	
CN2005	Main Blade Transport Supports		CN2208P	Metal Swashplate Anti-rotation Bracket - purple	
CN2007A	Trainer Pod 30-50 w/4 Legs		CN2213	2oz Header Tank w/ Machined Mount Bracket - purple	
CN2015	Hardened Tip Hex Wrench Set (1.5mm/2.0mm/2.5mm/3.0mm tips)		CN2214B	Air Filter (OS32-46, TT36-46)	
CN2016	4.8V Battery Monitor/Alarm		CN2215B	Machined Head Button (threaded) - black	
CN2018	PG-2000II Dual Rate Remote Gain Piezo Gyro		CN2215P	Machined Head Button (threaded) - purple	
CN2022	Single rate micro piezo gyro		CN2217P	Machined Color Caps - purple	
CN2046	Basic Heli Setup Tool Kit (pitch gauge, blade balancer & pliers)		CN2218P	Machined Color Washers - purple	
CN2052	Accuratech Blade Balancer - blue		CN2221	6mm Feathering Spindle System w/ Thrust Bearings	
CN2056	CNC Machined Aluminum Swashplate		CN2126H	Ultra Light Carbon Graphite Tail Boom	
CN2079	Fast 3-D Hot dog fly bar paddles (R red, O orange, Y yellow)		CN2239C	Carbon tail boom mount for rear rudder servo	
CN2137	2 oz Header Tank w/ Universal Bracket - purple		CN2240H	Carbon Graphite 3D Tail Fin Set	
CN2155	Piston Locking Tool - purple		CN2128H	Ultra Light Carbon Graphite Tail Boom Supports	
CN2153	Machined Throttle Extension - OS32SX,46FX, TT36H - purple		CN2400	Hurricane Carbon fiber Blades - 550mm Fully Sym	
CN2176	CNC machined servo arm pack (5 pcs. Futaba purple)		CN2501	Vortex Carbon fiber Blades - 550mm Fully Sym 3D Pro	
CN2177	CNC machined servo arm pack (5 pcs. JR purple)		CN265522	RotorTech Carbon Blades - 550mm Fully Sym 3D Sport	
CN2179H	CNC machined servo arm pack (5 pcs. Hitec purple)		CN3033	Speed torpedo 30 HV Muffler - Polished Aluminum	
CN2202	Aluminum Turbo cooling fan - purple		CN3055H	Millennium Pipe System - Polished Aluminum	
CN2275	CNC Machined Bell Mixing Arms (2)			See page 19-20 for upgrade photos.	

Hawk Pro Replacement Parts



HW3000
Hardware pack



CN0402
Hex start adapter



CN2226
Hardened start shaft



HI3007
Starter bearing blocks



HI3009
Cooling fan



HI3010
Clutch bell



HW3011
Clutch shoe



HW3017
Engine mount (.30 size)



HI3020A
Cooling fan shroud



HW3024
Collective pitch lever set



HI3031A
Aileron bellcrank set



HI3032B
Elevator lever set



HI3035A
Adjustable cyclic link set



HI3040
Counter drive gear



HW3042
Primary drive shaft



HW3045
Alloy drive gear



HW3050
Autorotation bearing set



HW3053A
Main shaft



HW3054A
Main shaft collar



HI3056
Main gear



HW3057
Tail transmission bevel gear



HW3059A
Tail drive primary shaft



HW3062
Tail boom pipe



HW3063TS
Tail drive shaft set



HW3064G
Tail control rod



HI3067A
Tail fin set



HW3070A
Tail gearbox input shaft



HW3073
Tail output shaft



HW3074
Tail output shaft spacer



HI3075
Tail gear set



HI3078
Tail gearbox



HI3087A
Tail pitch slider set



HI3089
Tail pitch ball links



HI3096
Tail blade grip set



HW3098
Tail rotor hub



HI3099
Tail rotor blades



HI3102A
Tail pitch lever



HI3106A
Tail pushrod guides



HI3107
Upper side frame set



HI3112C
Lower side frame set



HW3115A
Servo frame set



HI3122
Landing struts



HW3123
Landing skids



HW3127A
Canopy frame mounts



HI3129
Canopy front mounts



HI3130B
Canopy



HI3131M
Decal set



HI3133A
Windshield



HI3138A
Fuel tank parts set



HI3145
Ball link set



HI3146B
Swashplate set



HI3152C
Washout unit



HI3152A
Radius links



HI3160B
Main rotor hub



HW3161A
Seesaw pivot lever



HI3167A
Seesaw lever set



HI3167B
Seesaw offset plate



HI3167C
Seesaw tie bars



HI3167D
Seesaw Bearing cups



HI3167E
Special ball M3x6



HW3170A
Washout pins



HW3173
Flybar

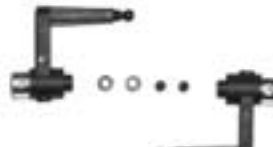

HI3176
Flybar control arm set



HI3179
Flybar paddle set



HW3180C
Feathering shaft set



HI3181
Dampening rubbers



HI3184
Main rotor blade grips



HI3189
Bell mixing arms

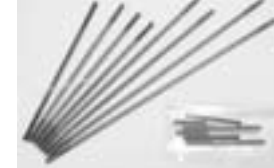

HW3192
Cyclic pushrod set



HW3202B
Tail boom support set



HW3204
Throttle lever



CN2322
Main rotor blades



HI3107A
M9x14 spacer (upper frames)



HW3065A
Torque tube bearing case



HW3065
Torque tube male end

Century Hawk Pro Upgrades

Fiber Glass Whip Antenna



Kit comes with a hollow fiber tube and CNC base mounts that allow you to insert antenna into the tube. Antenna will be better protected and look so cool.

CN2124-NG Antenna Neon Green
CN2124-NY Antenna Neon Yellow

CNC Machined Aluminum Servo Arm Pack

(for plastic output/gear servos)



Completely eliminate slop from flexing servo arms (purple)

CN2176 (Futaba) Arm set
CN2177 (JR/Air) Arm set
CN2179H (Hitec) Arm set

Color Machined Finish Cap & Washer



These caps and washers will add a lot to the looks of our Hawk Pro (colors: Silver, Red, Blue, Gold, Purple, green, black 10pcs/pack)

CN2217B (screw cap blue)
CN2218R (nut washer red)

Triple Ball Bearing Tail Blade Grips & One Piece Steel Hub

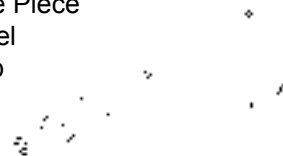

Heavy duty dual B.B and a trust bearing tail grip permits solid precise control. One piece hardened steel hub for long-lasting precision and durability.

CN2235 Triple B.B tail assembly

Tuff landing Gear Systems



3 times stronger than most 30-50 size helicopter landing gear. Tuff struts act as shock absorbers to help reduce jolts caused by hard landing.

CN2243 Tuff landing gear

Reversible Hex One Way & Hex Start System



Adapts to starter shaft push into rubber insert. Extension adapts to most starters.

CN0426 Standard hex wand
CN0427 One-way hex start ext.

Color Machined Lock Nut w/Flange

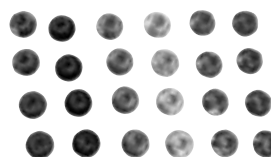

(color: silver, red, blue, gold, purple & black 10pc pack.

CN2211B lock nuts blue
CN2211BK lock nuts black
CN2211R lock nuts red
CN2211G lock nuts green
CN2211S lock nuts silver

Millenium Tuned Pipe System



This tuned pipe flattens the power band while boosting additional 10-15% of the overall power from the engine.

CN3055H Tuned Pipe Set

Neon Color 3-D Paddles



Speed up your 3D cyclic response with these lightning quick paddles!

CN2079Y (Neon Yellow)
CN2079R (Glow Red)
CN2079O (Glow Orange)

3-D Carbon Fin set



3D Hot Dog pilots will love this light and durable carbon fiber tail fin set.

CN2240H Tail Fin set

Main Shaft Thrust Bearing Kit

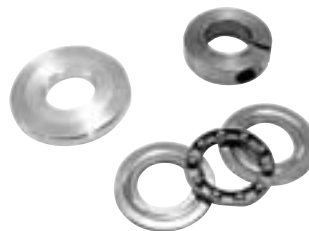

Transfers all loading from the regular radial bearings to the thrust bearing.

CN2220A Thrust Bearing Kit

50 size engine motor mount



Convert side frames to take up to the O.S. 50 Engine

CN2251 O.S. 50 Conversion

Carbon Fiber Tail Boom



Get that attractive woven Carbon Fiber look with these light carbon fiber tail booms

CN2126H Carbon tail boom

O.S. Throttle Extension



Aluminum C.N.C. machined throttle extension for OS32SXH, 46FXH and TT36H (purple)

CN2153 Throttle extension

Crash Kit



Hawk Pro crash kit includes 550mm main blade, tail boom, feathering shaft, 10mm main shaft, flybar.

CN2230H4 Hk Pro crash kit

Carbon Graphite Tail Boom Support



Super high quality, extremely light weight and ready to install dual tail boom support kit.

CN2128 Carbon Support

Century Hawk Pro Upgrades

Head Button (Hawk, Falcon & Phoenix)

Left hand threaded Black or Purple anodized head button for easy stopping of the rotor head.



CN2215B Black
CN2215P Purple

Fiber Glass Canopy with Carbon Support



CN2242B Light Blue
CN2242G Light Green
CN2242Y Light yellow

Metal Bell Mixer Arm Set



Remove slop transferring to blade grips.

CN2275A Metal color
CN2275P Purple color

2 oz Header Tank w/ CNC Machined or Die-cut Mount

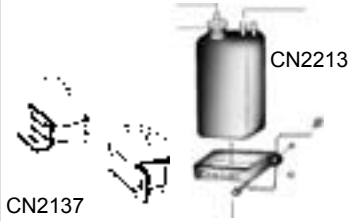

CN2137

Get 2 extra ounces of fuel and reduce any fuel foaming in one easy step!

CN2213 Machined Mount
CN2137 Die Cut Mount

4mm Flybar upgrade



More rigid and precise flybar improves cyclic response

CN2232 4mm flybar upgrade

CCPM Conversion



Outstanding for rigid, slop free elevator control.

CN1061A CCPM conv. 10mm

Aluminum Turbo Cooling Fan



Increased air flow, lower engine drag, cooler and smoother high speed operation & cooler clutch shoes.

CN2202 Turbo cooling fan

Metal Swash Plate Anti-rotation Bracket



Improves timing precision of the swash plate (purple or black)

CN2208P Purple
CN2208B Black

Constant Tail Drive

Descending or in autorotations, full tail rotor control is maintained in proportion to the main rotor speed.



CN2263A Constant Tail Drive

Aluminum Clutch Bell

CNC precision machined aluminum clutch bell with replaceable gear and lining



CN2225 Clutch bell w/gear
HI3010A Bell only
HI3010B 2-Stroke Gear (26T)
CN2020L Clutch lining (2)

Precision Metal Swashplate



This beautiful CNC precision machined aluminum swashplate will increase precision control for all flight maneuvers. (Silver)

CN2056 Metal Swashplate

SE 6 mm Head Axle with Thrust Bearings

The 6mm spindle takes the high "G" stresses of 3D better and the thrust bearings make for smoother pitch control at high rotor speeds



CN2221 Conversion Kit

Extra hard Rubber dampeners

Get extra supercrisp flying with hard cyclic dampeners. Soft fluttering will switch to lightning quick response



HI3181A 85 degree hardness damping rubbers

RotorTech Carbon High performance main blades



The ultimate competition winning carbon blade. 6 out of 10 professional pilots choose RotorTech!

CN265501 carbon angle tip 550mm
CN265522 carbon flat tip 550mm

RotorTech Carbon High performance tail blades



The ultimate competition winning carbon tail blade. Maximum tail control is yours!

CN260853 carbon tail blades 85mm

CENTURY

HELICOPTER PRODUCTS

Century Helicopter Products
1740 Junction Ave. C.
San Jose, CA 95112
Fax: (408) 451-1156
www.centuryheli.com

All rights reserved. No part of this publication may be reproduced, stored in a retrieval system or transmitted in any form or by any means, electronic, mechanical, photocopying, recording or otherwise, without the prior written permission of the publisher, Century Helicopter Products.