

The R/Cer's Partner

FOCUS 2 SS AM/FOCUS 3 SS AM
INSTRUCTION MANUAL

ENGLISH 2/01

CONTENTS

INTRODUCTION

LAY-OUT DIAGRAM

FEATURES AND SPECIFICATIONS

SETTING AND OPERATION

1. TRANSMITTER

- **Loading batteries**
- **Reading the LED Battery Indicators**
- **Recharging NiCad Batteries**
- **Changing X-Tals**

2. Installation of Receiver and Servos

3. Transmitter, Receiver and servo settings

- **Checking operation of the servo**
- **Elevator and Rudder Servo Trim Settings**
 - a. Trim setting before flight**
 - b. Trim setting during flight**

INTRODUCTION

The Focus 2 and 3 Single Stick radios were specifically made for simple 2 and 3 channel Electric, 1/2 A and Sailplane applications. It was ergonomically designed to allow the user to hold onto transmitter with one hand, while launching the aircraft with the other. The Focus 2 and 3 SS will prepare you to use radios with more advanced features as your skill level and desire for greater challenges evolve.

LAY-OUT DIAGRAM

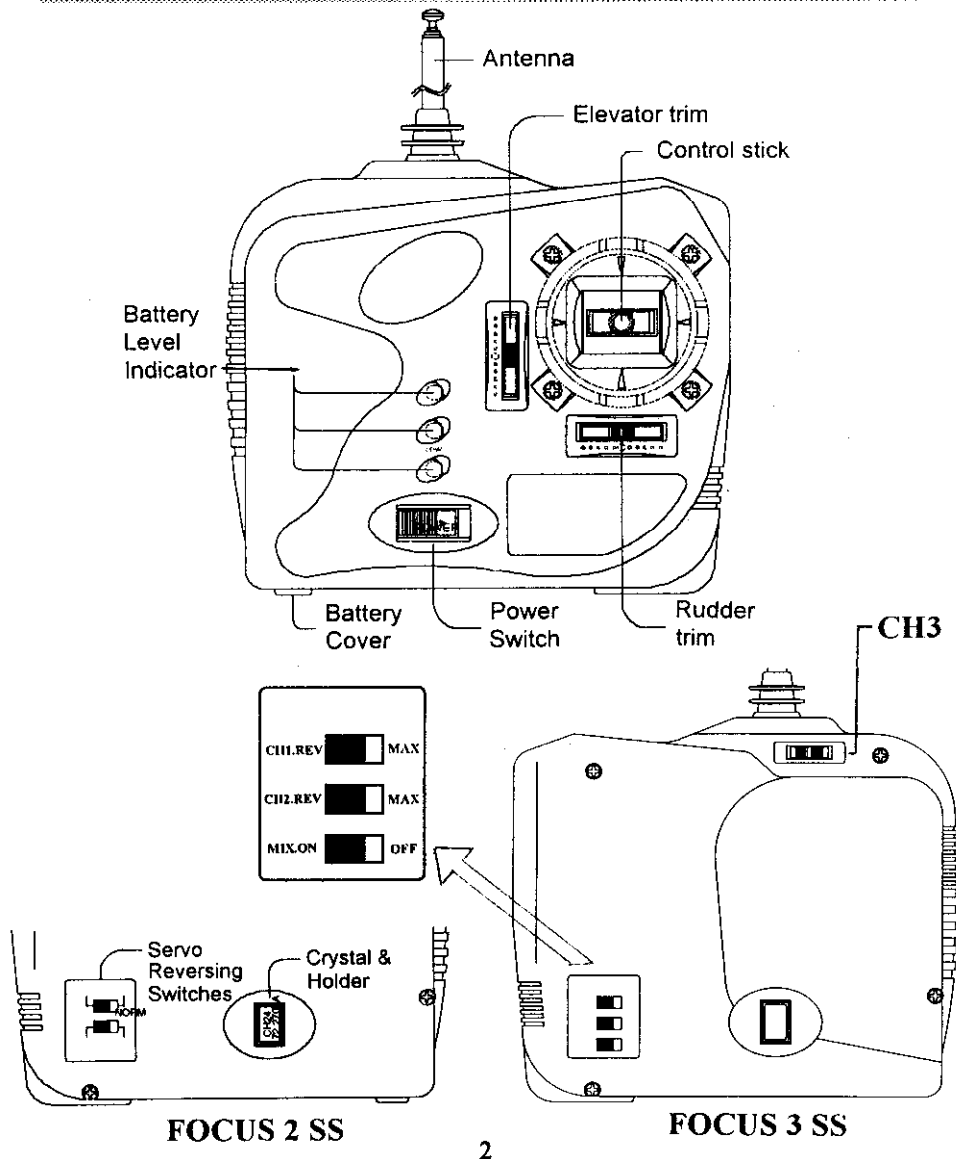

FEATURES AND SPECIFICATIONS

TRANSMITTER

Single stick 2 and 3 channel proportional system

AM modulated signal

Dual axis precision gimbal

3 L.E.D battery status indicator lights

Charging jack for optional Nicads

Servo reversing for channels 1 and 2

Current drain : 180mA

V-tail or Elevon mixing function (Focus 3 only)

Proportional 3rd. channel slide switch (Focus 3 only)

RECEIVER

- Narrow Band 2 or 3 channel AM receiver
- Battery Eliminator Circuit
- Excellent adjacent channel rejection
- Voltage : 4.8 V ~ 6.0 V
- Current drain : 48 mA

SERVO

- High impact plastic gear
- Hitec Custom I.C.
- High reliability SMT circuit

SETTING AND OPERATION

1. TRANSMITTER

• Loading batteries

You may use either Alkaline "AA" size batteries or optional NiCad batteries. (NiCads Recommended)

- * Push the bottom battery cover in the direction of the arrow then lift up the cover
- * Load 8 AA batteries (Be sure the polarity is correct)
- * Reinstall battery case with installed AA batteries with connections to the top left
- * NiCads should be charged before use

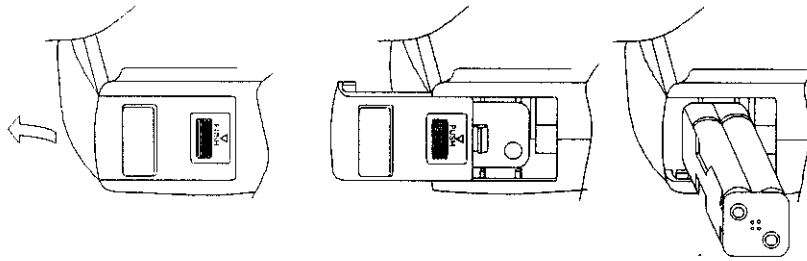

• **Reading the LED Battery Indicators**



Full Power: *Green* Normal: *Amber* Warning: *Flashing Red*

With new alkaline or freshly charged NiCads, the *Green* light should be lit. With use, the *Green* light will turn to *Amber*. If the *Red* begins to flash, operation should be stopped and the batteries should be recharged or replaced immediately.

• **Recharging NiCad Batteries**

The Focus 2 SS and 3 SS is equipped with an external charging jack so there is no need to remove the battery pack from the transmitter. The Hitec *CG-22A* or *25A* are made to charge these type of batteries overnight or for approximately 12-15 hours. Please refer to the following diagram, check to see that the charge lights lit after the connection is complete. It is advisable to cycle your batteries at least once every 5 or 6 charges. This can be done by simply turning your transmitter on with the antenna connected and extended to let it run completely dead (**Warning!!! Always extend your antenna as not to overload the circuitry when radio is on.**), then follow the charging method and repeat this 3 times, this will remove the memory that the battery has stored up if you just simply charge a half dead pack.

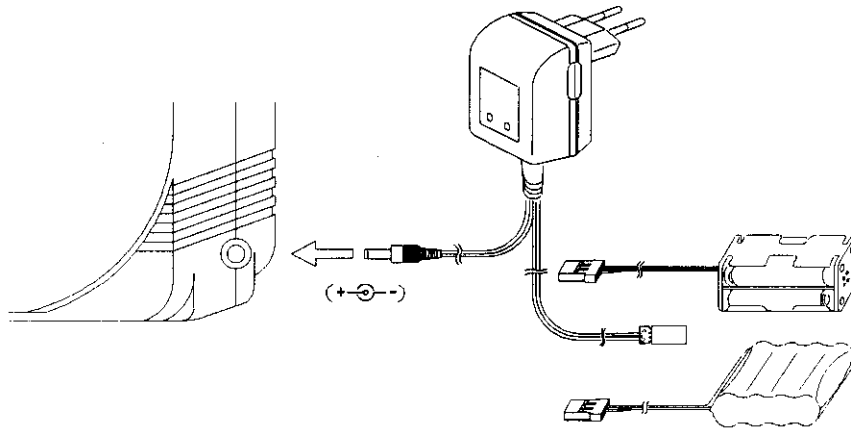

• Changing X-Tals

Changing X-Tal to avoid conflicts with other vehicles is possible where permitted. (You must check your local rules before doing so. For example in the US the FCC prohibits the changing of transmitter X-Tals on 72 and 27mhz). If you are allowed to change X-tals, both the transmitter and receiver X-tals must be changed together. You must change within the same band, i.e. 72 MHz to 72 MHz , 27 MHz to 27 MHz, different bands can not be intermixed if your radio is on 72 MHz then 27 MHz X-tals cannot be used. *Use only Hitec X-tal when changing frequencies.*

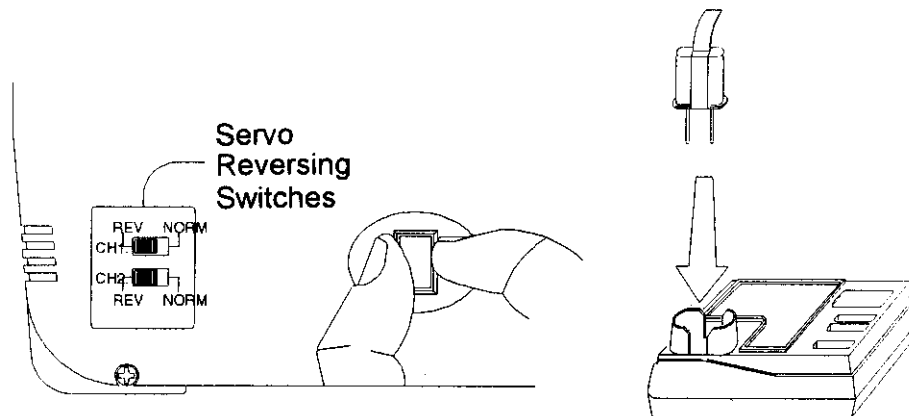

2. Installation of Receiver and Servos

After connecting the receiver and servos as below illustration, turn on the power to the transmitter first then turn the receiver on (*Always turn the transmitter ON first and OFF last.*) This will prevent the receiver from picking up stray signals and going out of control. Now, move the controls to see if the servos are moving

properly. If not, check your wiring or X-tals if the servos do not move at all.

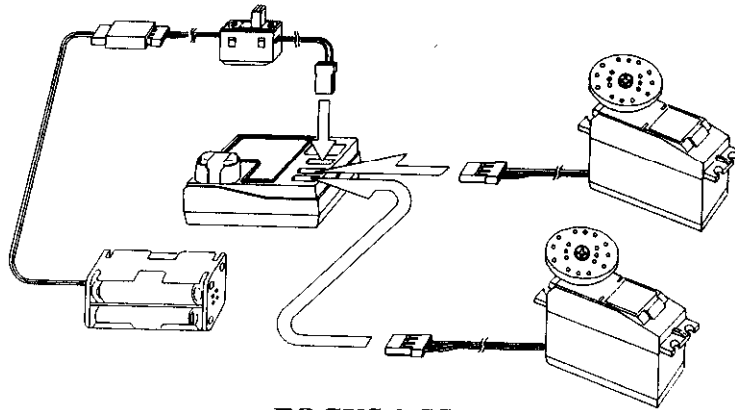

FOCUS 2 SS

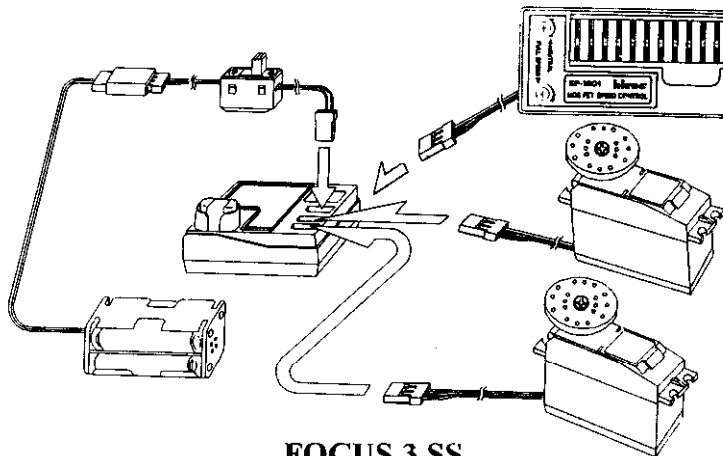

FOCUS 3 SS

3. Transmitter, Receiver and servo settings

Now we come to the critical part as proper installation of these components is essential.

- **Checking operation of the servo**

- * After installation of the servo and receiver into your model is complete, turn the power "ON" the transmitter (*fully extend the antenna*) now turn on the receiver.

- (Note : Do not connect the linkage to the servos until the servo test procedure is completed as unexpected movement may damage the servos or the model)

- * Check to see if all servos are working properly. If not, check the connections and/or make sure the main battery pack is charged.
- * If the servos check out fine, connect the linkage to the servo horns now. Check to see that the servos are moving in the correct direction. If not, change the servos direction with the reversing switches located on the back of the radio.
The 3rd channel of the Focus 3 SS is not reversible.
- * If everything checks out then turn the receiver "OFF" first, then the transmitter.

The Focus 3 SS offers an internal electronic mix for channels 1 and 2 to deliver an Elevon or V-tail mix for those aircraft requiring those specific functions.

(Always remember to Never have the receiver "ON" without the transmitter being "ON". This means when turning your model "ON" always turn the transmitter "ON" first and "OFF" last)

(Note : Please make sure to fold the transmitter antenna after use so as not to get damaged or poke someone in the eyes)

Warning!!! : Do not shorten the length of the receiver antenna by cutting off any excess wire. This will severely affect the operating range and could result in injury to yourself and others..

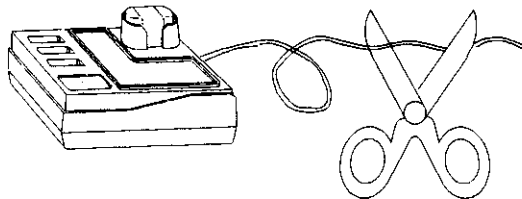

• **Elevator and Rudder Servo Trim Setting**

a. Trim setting before flight

The servo trim enables minor adjustment of the servo neutral position so that the plane will fly straight when the stick is in the center position. Before adjusting the servo trim, please make sure that when both the stick and the servo trim is in its center position, (1) the servo arm is perpendicular to the push rods, and (2) the elevator and rudder of the plane is flush with the tail wing.

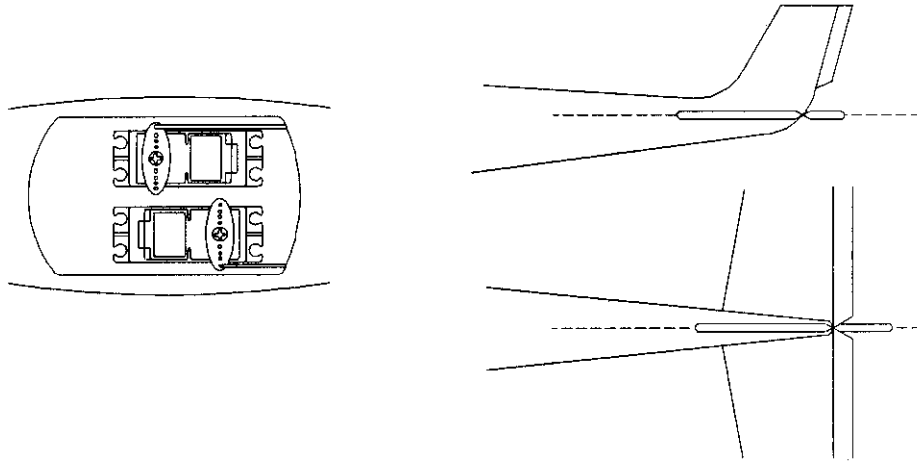

b. Trim setting during flight

You may perform some minor trim adjustment during flight if the plane nose up or down (Elevator trim) or sideways (Rudder Trim) when the stick is in the center position. However please keep in mind that trim adjustment is only for minor adjustment and major adjustment should still be done through push rod (linkage) adjustment at the model.

(Note: There is no trim adjustment on the 3rd channel of the Focus 3 SS)

- When your plane does this

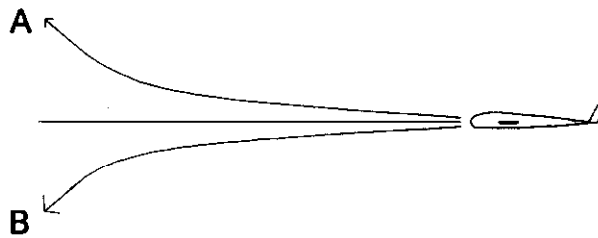

- Move trim like below

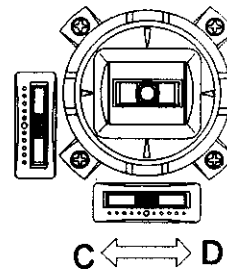
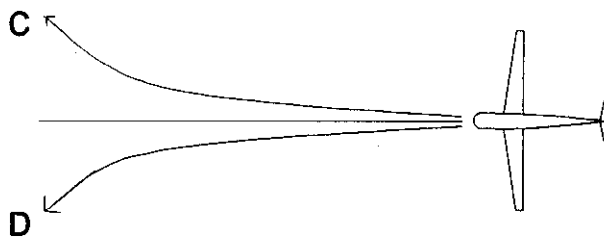
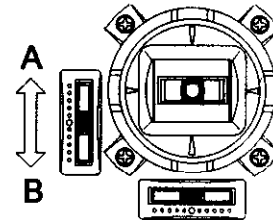

For U.S.A.

This device complies with Part 15 of the FCC rules. Operation is subject to the following two conditions : (1) this device may not cause harmful interference, and (2) this device must accept any interference that may cause undesired operation.

Transmitter frequencies can only be changed by an authorized Hitec RCD service center. Changing frequencies by the consumer will void the warranty and is a violation of F.C.C regulations.

**FOCUS 2 SS AM/FOCUS 3 SS AM
INSTRUCTION MANUAL**

